

LUBRICATION SYSTEM

OUTLINE	2- 2
LUBRICATION CIRCUIT	2- 2
SPECIFICATIONS	2- 3
TROUBLESHOOTING GUIDE	2- 3
INSPECTION	2- 4
ENGINE OIL	2- 4
OIL PRESSURE	2- 4
ENGINE OIL	2- 4
REPLACEMENT	2- 4
OIL FILTER	2- 5
REPLACEMENT	2- 5
OIL COOLER	2- 5
REMOVAL AND INSTALLATION	2- 5
OIL PAN	2- 6
REMOVAL	2- 6
INSPECTION	2- 7
INSTALLATION	2- 7
OIL PUMP	2- 8
REMOVAL	2- 8
DISASSEMBLY	2- 9
INSPECTION	2- 9
ASSEMBLY	2-10
INSTALLATION	2-10

86U02X-001

2 OUTLINE

OUTLINE

LUBRICATION CIRCUIT

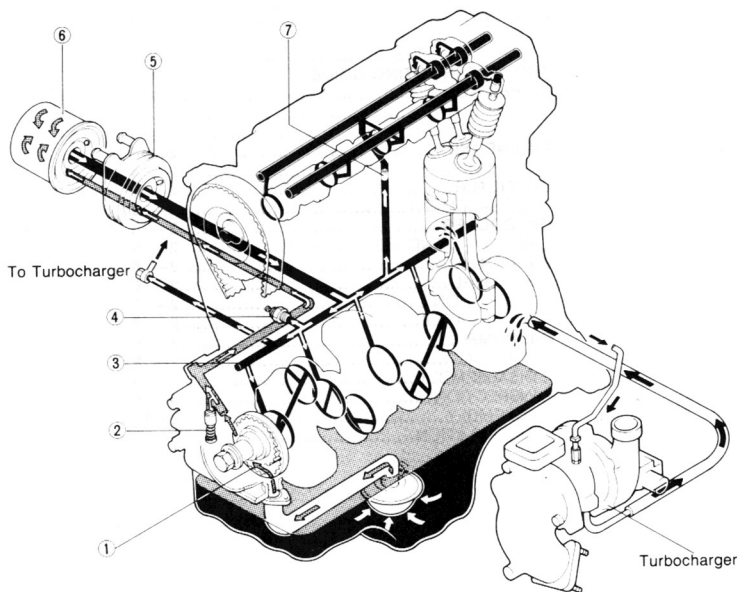

86U02X 003

1. Oil pump
2. Pressure regulator valve
3. Main gallery
4. Oil pressure switch

5. Oil cooler (only Turbo)
6. Oil filter
7. Oil control plug

SPECIFICATIONS

Item	Engine model		F2	
			Turbo	Non-Turbo
Lubrication system			Force-fed	
Oil pump	Type		Trochoid gear	
	Regulated pressure	kPa (kg/cm ² , psi)	294–392 (3.0–4.0, 43–57)	
	Oil pressure	kPa (kg/cm ² , psi)—rpm	147–245 (1.5–2.5, 21–36)—1,000 294–392 (3.0–4.0, 43–57)—3,000	
Oil filter	Type		Full-flow, paper element	
	Relief pressure differential	kPa (kg/cm ² , psi)	78–118 (0.8–1.2, 11–17)	
Oil cooler	Type		Water-cooled, 4 stage	
Oil warning pressure		kPa (kg/cm ² , psi)	29 (0.3, 4.3)	
Oil capacity	Total (dry engine)	liters (US qt, imp qt)	4.6 (4.9, 4.0)	
	Oil pan	liters (US qt, imp qt)	3.9 (4.1, 3.4)	
	Oil filter	liters (US qt, imp qt)	0.3 (0.32, 0.26)	
Engine oil (API service)			SF, SG	

96U02X 001

Recommended SAE Viscosity

Temperature	(°C)	-30	-20	-10	0	10	20	30	40	50	
	(°F)	-20	0	20	40	60	80	100	120		
Engine oil		5W-30		30							
		5W-20		20W-20		40					
		10W-30									
		10W-40			10W-50						
		20W-40				20W-50					

Temperature range anticipated before next oil change, °C(°F)

63G02D 303

TROUBLESHOOTING GUIDE

Problem	Possible Cause	Remedy	Page
Engine hard starting	Improper engine oil	Replace	2–4
	Insufficient engine oil	Add oil	2–4
Excessive oil consumption	Oil working up or working down	Refer to Section 1	—
	Oil leakage	Repair	—
Oil pressure drop	Insufficient oil	Add oil	2–4
	Oil leakage	Repair	—
	Worn or damaged oil pump gear (outer and inner rotor)	Replace	2–9
	Worn plunger (inside oil pump) or weak spring	Replace	2–9
	Clogged oil strainer	Clean	—
	Excessive main bearing or connecting rod bearing clearance	Refer to Section 1	—
Warning lamp illuminated while engine running	Oil pressure drop	As described above	—
	Malfunction of oil pressure switch	Refer to Section 15	—
	Malfunction of electrical system	Refer to Section 15	—

96U02X 013

2 INSPECTION, ENGINE OIL

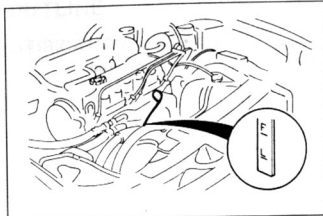

86U02X-004

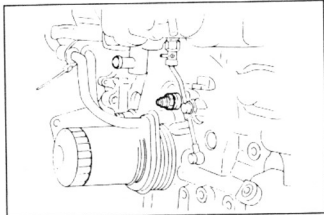

69G02A-006

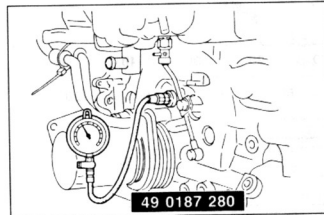

96U02X-002

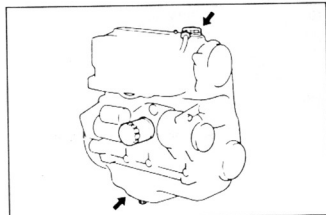

86U02X-006

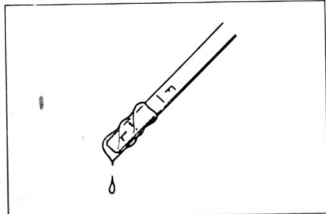

96U02X-003

INSPECTION

ENGINE OIL

1. Be sure the vehicle is on level ground.
2. Warm up the engine to normal operating temperature and stop it.
3. Wait for five minutes.
4. Remove the oil level gauge and check the oil level and condition.
5. Add or replace oil if necessary.

Note

The distance between the L and F marks on the level gauge represents 1.0 liter (1.06 US qt, 0.88 Imp qt).

OIL PRESSURE

1. Remove the oil pressure switch.
2. Screw the SST into the pressure switch installation hole.
3. Warm up the engine to normal operating temperature.
4. Run the engine at **3,000 rpm**, and note the gauge reading.

Oil pressure:

147—245 kPa

(1.5—2.5 kg/cm², 21—36 psi)—1,000 rpm

294—392 kPa

(3.0—4.0 kg/cm², 43—57 psi)—3,000 rpm

5. If the pressure is not as specified, check for the cause, and repair if necessary.
(Refer to Troubleshooting Guide.)

ENGINE OIL

REPLACEMENT

1. Warm up the engine to the normal operating temperature and stop it.
2. Remove the oil filler cap and the oil pan drain plug.
3. Drain the oil into a suitable container.

Warning

Be careful when draining, the oil is very hot.

4. Install the drain plug and a new gasket.
5. Refill the engine with the specified type and amount of engine oil.
6. Refit the oil filler cap.

Oil pan capacity:

3.9 liters (4.1 US qt, 3.4 Imp qt)

7. Recheck the oil level after the engine has been run.

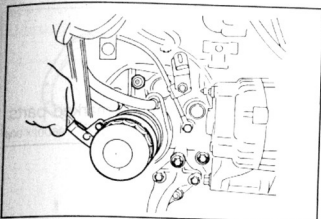

86U02X-008

OIL FILTER

REPLACEMENT

1. Remove the oil filter with a suitable wrench.
2. Use a clean rag to wipe off the mounting surface on the engine.
3. Apply a small amount of engine oil to the rubber seal of the new filter.
4. Install the oil filter and tighten it by hand only. Do not use a wrench.
5. Start the engine and inspect around the filter seal for leaks.
6. Check the oil level and add oil if necessary.

Oil filter capacity:

0.30 liters (0.32 US qt, 0.26 Imp qt)

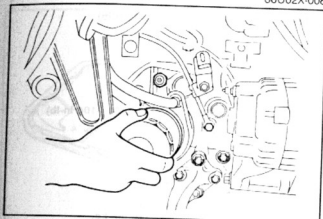

86U02X-009

OIL COOLER (Only Turbo)

REMOVAL AND INSTALLATION

Remove in the sequence shown in the figure. Install in the reverse order of removal.

1. Water hose
2. Oil filter
3. Nut
4. Oil cooler

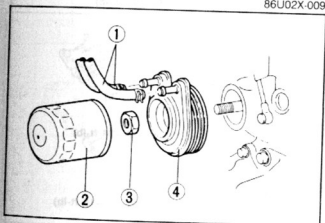

86U02X-010

Nut tightening torque:

29—39 N·m (3.0—4.0 m·kg, 22—29 ft·lb)

2 OIL PAN

OIL PAN

REMOVAL

1. Disconnect the negative battery cable.
2. Drain the engine oil.
3. Remove in the sequence shown in the figure, referring to the removal note for specially marked parts.

96U02X-004

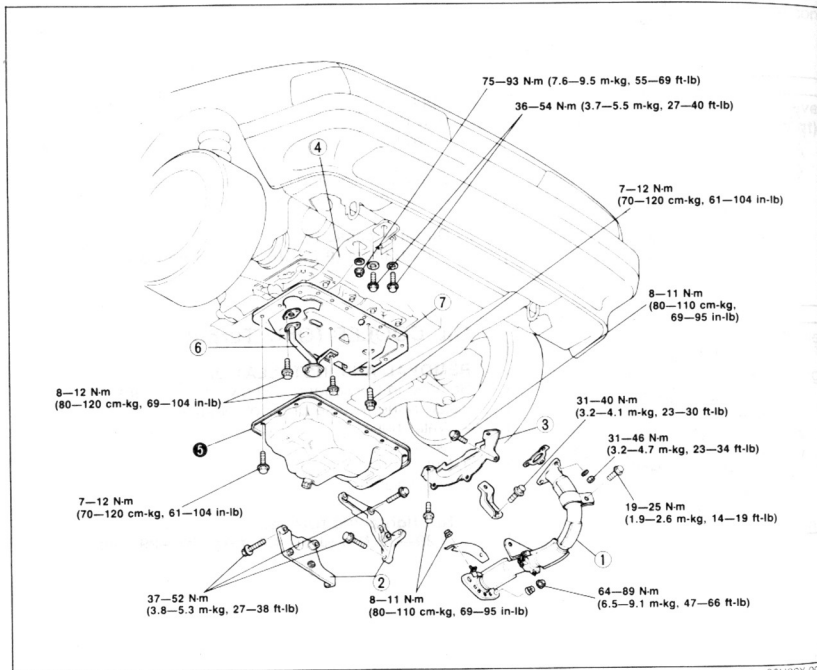

96U02X-005

1. Exhaust pipe
2. Gusset plate
3. Clutch housing under cover
4. Sub frame (RH)
5. Oil pan
6. Oil strainer
7. Stiffener

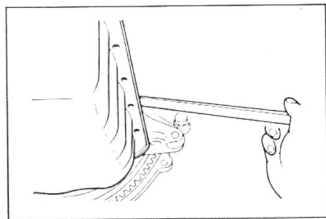

96U02X-006

Removal Note

Oil pan

1. Remove the oil pan mounting bolts.
2. Insert a scraper or a suitable tool between the oil pan and the stiffener to separate them.
3. Remove the oil pan.

Caution

Do not bend the oil pan when prying loose.

INSPECTION

Check the following points. Repair or replace if necessary.

1. Cracks, deformation, damage
2. Damaged drain plug threads

INSTALLATION

Install in the reverse order of removal, referring to the installation note.

Installation Note**Stiffener, oil strainer, and oil pan**

1. Remove any dirt or other material from the contact surface.
2. Apply silicon sealant to the stiffener around the inside of the bolt holes and overlap the ends.
3. Install the stiffener.

Tightening torque:

7—12 N·m (70—120 cm·kg, 61—104 in·lb)

4. Install the oil strainer and a new gasket.

Tightening torque:

8—12 N·m (80—120 cm·kg, 69—104 in·lb)

5. Apply a continuous bead of silicon sealant to the oil pan around the inside of the bolt holes and overlap the ends.

Caution

Secure the stiffener and oil pan within 30 minutes after applying the sealant.

6. Install the oil pan.

Tightening torque:

7—12 N·m (70—120 cm·kg, 61—104 in·lb)

Steps After Installation

1. Supply the specified amount and type of oil.
2. Start the engine and check for leakage.

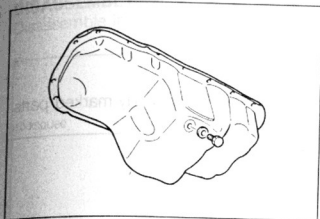

4BG02X 037

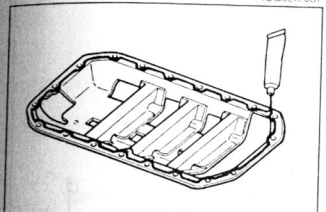

96U02X 007

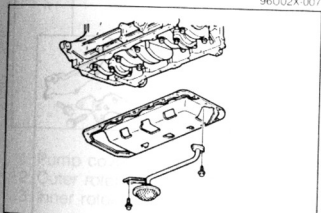

96U02X 006

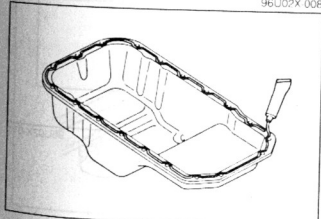

96U02X 009

2 OIL PUMP

OIL PUMP

REMOVAL

1. Disconnect the negative battery cable.
2. Drain the engine oil.
3. Remove in the sequence shown in the figure, referring to the removal note for specially marked parts.

96U02X-010

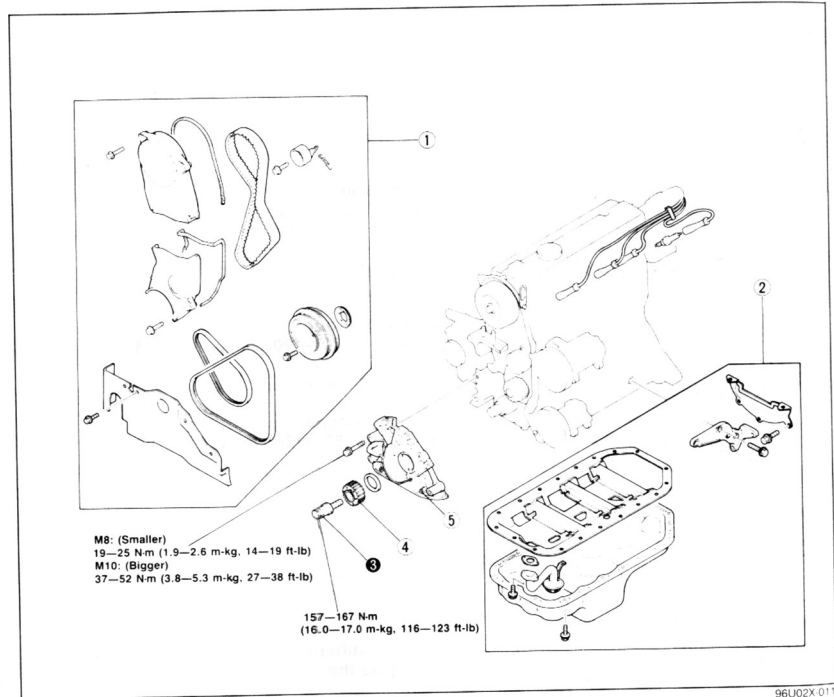

96U02X-011

1. Timing belt (Refer to Section 1)
2. Oil pan (Refer to page 2—6)
3. Timing belt pulley lock bolt

4. Timing belt pulley
5. Oil pump

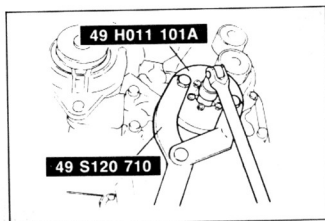

76G02A-026

Removal Note

Timing belt pulley lock bolt

Hold the timing belt pulley with the SST and remove the lock bolt.

DISASSEMBLY

Disassemble in the sequence shown in the figure.

69G02B 012

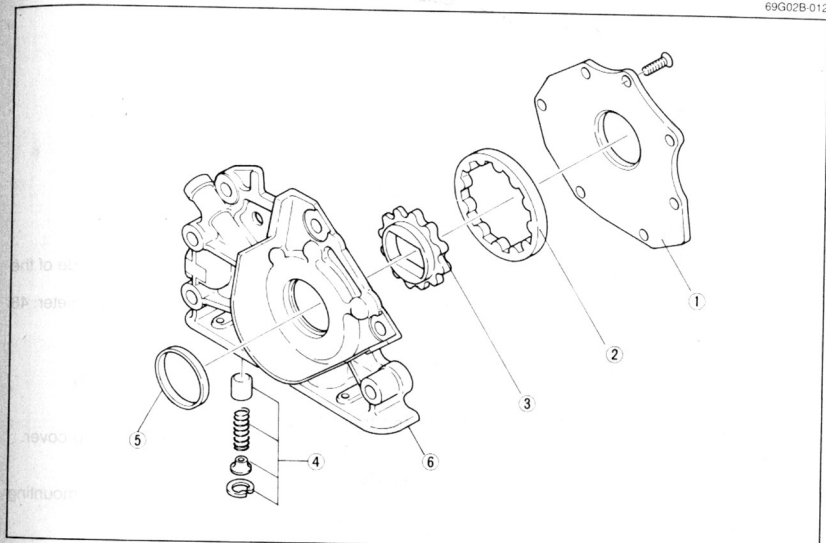

69G02B 013

1. Pump cover
2. Outer rotor
3. Inner rotor

4. Pressure relief valve
5. Oil seal
6. Oil pump body

INSPECTION

1. Check the following and replace any faulty parts.
 - (1) Distorted or damaged oil pump body or cover
 - (2) Worn or damaged plunger
 - (3) Weak or broken plunger spring
2. Measure the side clearance.

Clearance: 0.10 mm (0.004 in) max.

3. Measure the tooth tip clearance.

Clearance: 0.18 mm (0.007 in) max.

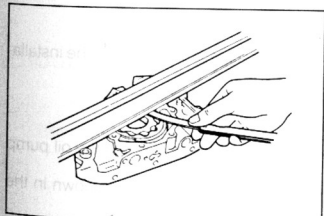

86U02X-020

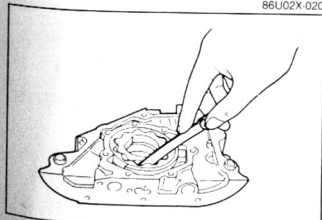

69G02B 015

2 OIL PUMP

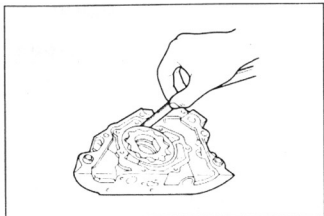

96U02X-014

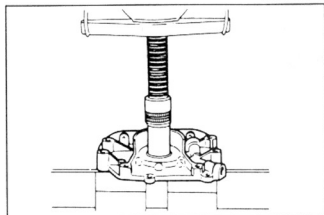

96U02X-016

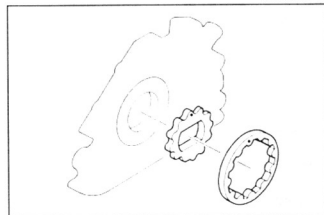

96U02X-015

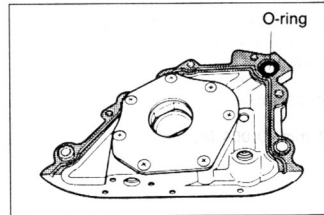

96U02X-012

4. Measure the outer rotor to pump body clearance.

Clearance: 0.20 mm (0.008 in) max.

ASSEMBLY

Assemble the pump as follows.

Oil Seal

1. Apply engine oil to the pump body and the outside of the new oil seal.
2. Press in the oil seal with a suitable pipe (outer diameter: 48 mm (1.89 in)).

Pressure Relief Valve

1. Install the plunger and spring in the pump body.
2. Fit the snap ring.

Outer and Inner Rotor

Install the rotors with the dimples facing the pump cover.

Oil Pump Cover

1. Apply thread locking compound to the cover mounting screws' threads.
2. Attach the oil pump cover to the body.

Tightening torque:

6—9 N·m (60—90 cm·kg, 52—78 in·lb)

3. Check that the rotor turns smoothly.

INSTALLATION

Install in the reverse order of removal, referring to the installation note.

Installation Note

Oil pump

1. Apply grease to a new O-ring and install it in the oil pump body.
2. Apply silicon sealant to the shaded area as shown in the figure.
3. Apply engine oil to the oil seal lip.

Steps After Installation

1. Supply the specified amount and type of oil.
2. Start the engine and check for leakage.