

MANUAL TRANSAXLE (H5M-R)

INDEX	J2- 2
OUTLINE	J2- 3
SPECIFICATIONS.....	J2- 3
STRUCTURAL VIEW.....	J2- 4
POWER FLOW	J2- 5
TROUBLESHOOTING GUIDE	J2- 6
TRANSAXLE OIL	J2- 7
INSPECTION.....	J2- 7
REPLACEMENT.....	J2- 7
TRANSAXLE	J2- 8
PREPARATION	J2- 8
REMOVAL	J2-10
DISASSEMBLY	J2-12
INSPECTION	J2-23
ASSEMBLY	J2-26
INSTALLATION.....	J2-43
SHIFT MECHANISM	J2-48
REMOVAL / INSTALLATION.....	J2-48
INSPECTION.....	J2-49

16U0J2-024

INDEX

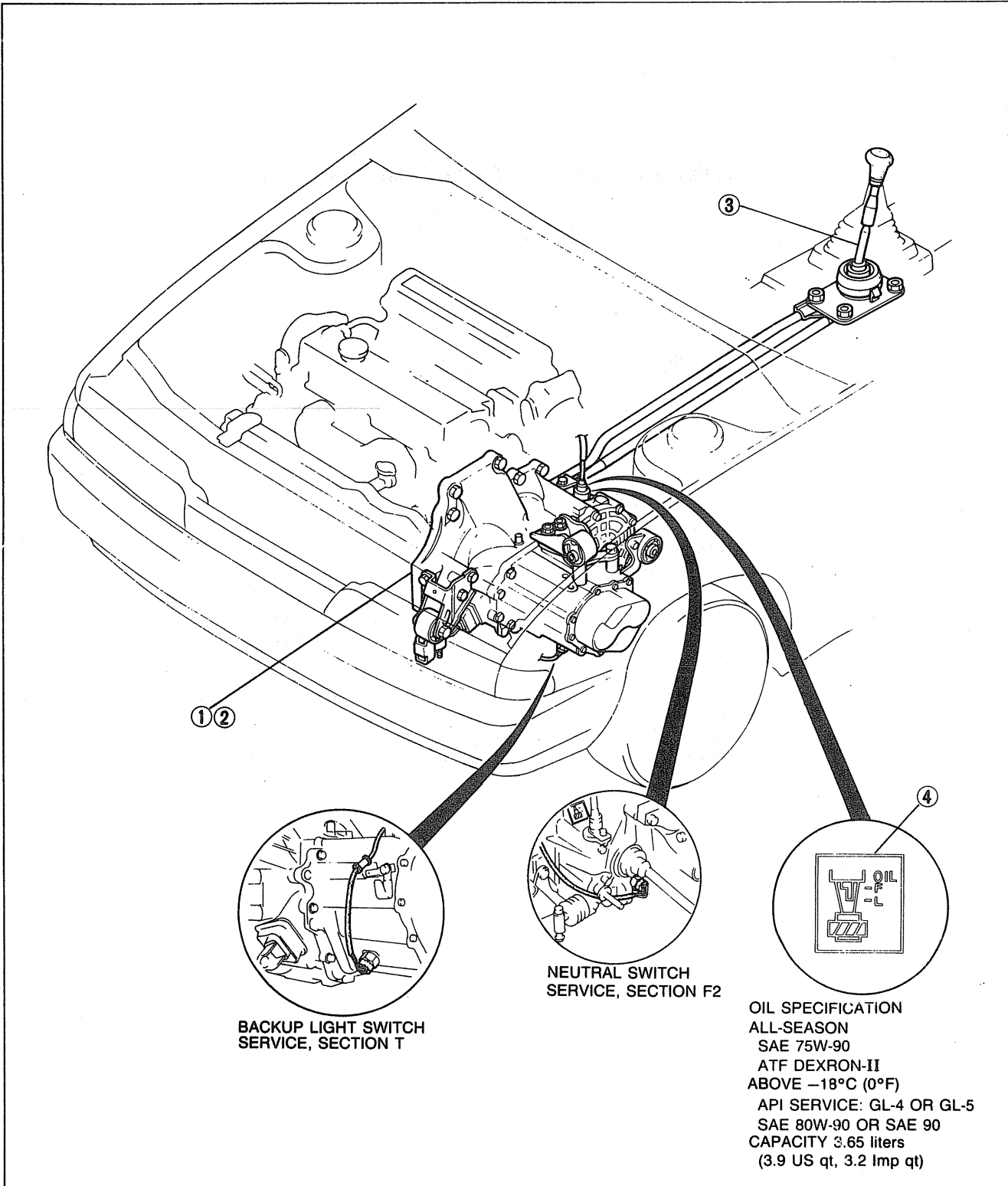

06U0J2-002

1. Transaxle

Removal page J2-10
 Disassembly ... page J2-12
 Inspection page J2-23
 Assembly page J2-28
 Installation..... page J2-43

2. Differential

Disassembly ... page J2-21
 Inspection page J2-23
 Adjustment page J2-27
 Assembly page J2-26

3. Shift mechanism

Removal /
 Installation..... page J2-48
 Inspection page J2-49

4. Transaxle oil

Inspection page J2- 7
 Replacement .. page J2- 7

OUTLINE

SPECIFICATIONS

Item		Engine	F2 Turbo
Transaxle model			H5M-R
Transaxle control			Floor shift
Synchromesh system			Forward.....synchromesh, Reverse.....selective sliding and synchromesh
Gear ratio	1st		3.250
	2nd		1.772
	3rd		1.194
	4th		0.926
	5th		0.711
	Reverse		3.461
Final gear ratio			4.105
Oil	Type	All season SAE 75W-90 ATF: DEXRON-II	Above -18°C (0°F) API: GL-4 or GL-5 SAE 80W-90 or SAE 90
	Capacity	3.65 liters (3.9 US qt, 3.2 Imp qt)	

J2

16U0J2-001

STRUCTURAL VIEW

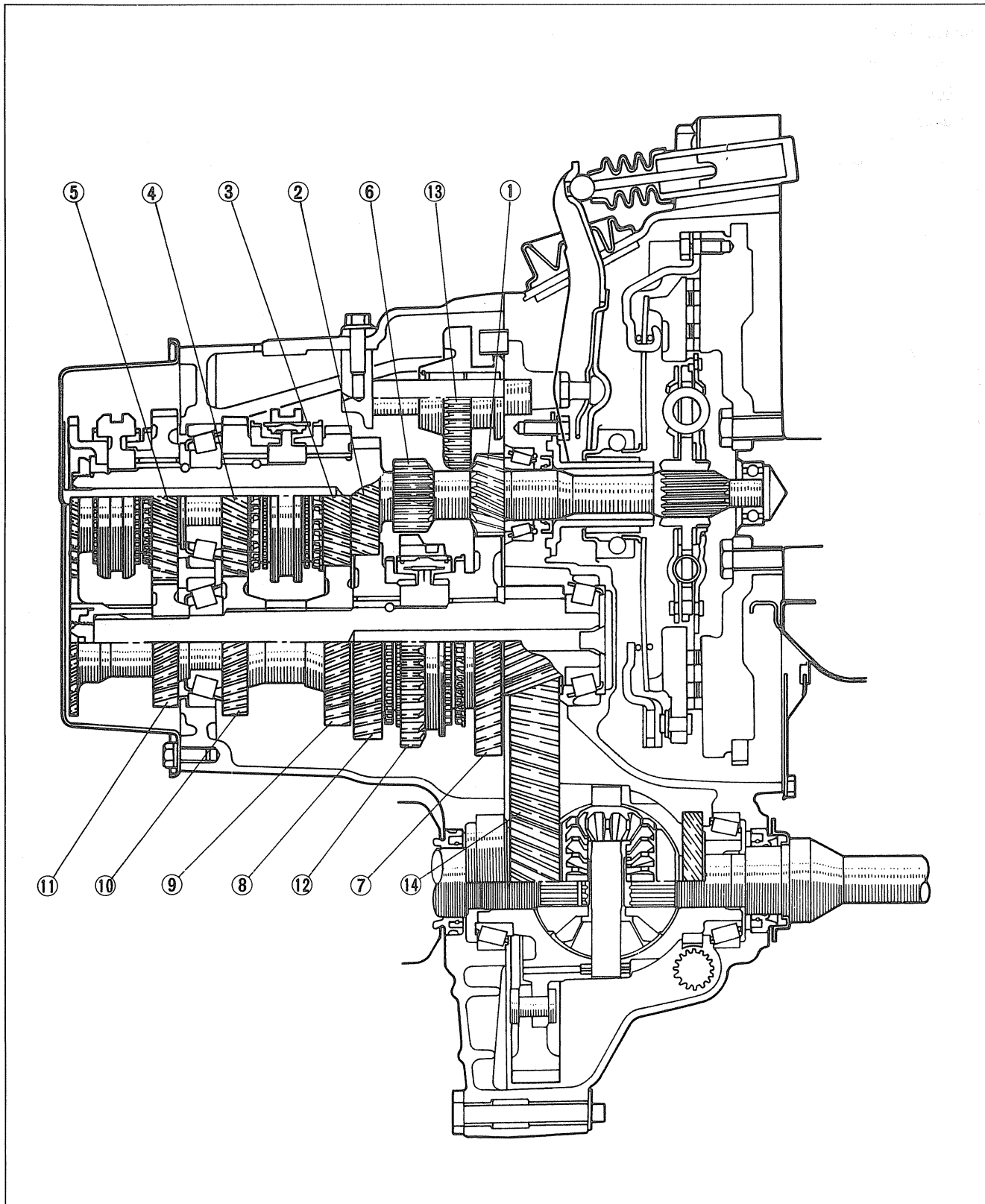

06U0J1-004

- 1. Primary 1st gear
- 2. Primary 2nd gear
- 3. Primary 3rd gear
- 4. Primary 4th gear
- 5. Primary 5th gear

- 6. Primary reverse gear
- 7. Secondary 1st gear
- 8. Secondary 2nd gear
- 9. Secondary 3rd gear
- 10. Secondary 4th gear

- 11. Secondary 5th gear
- 12. Secondary reverse gear
- 13. Reverse idler gear
- 14. Differential

POWER FLOW

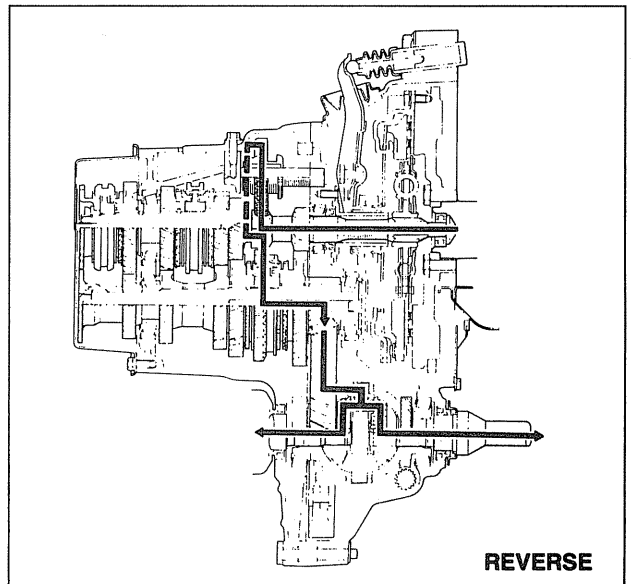
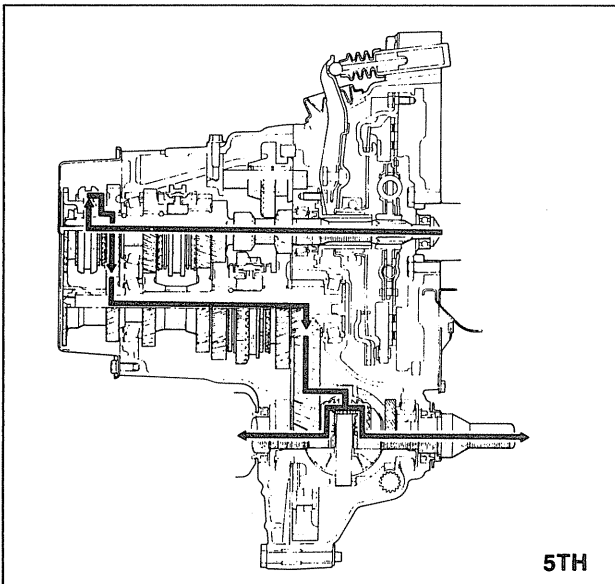
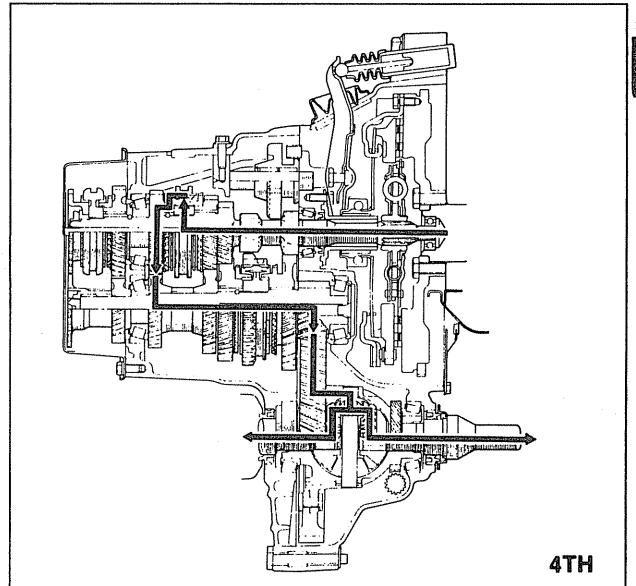
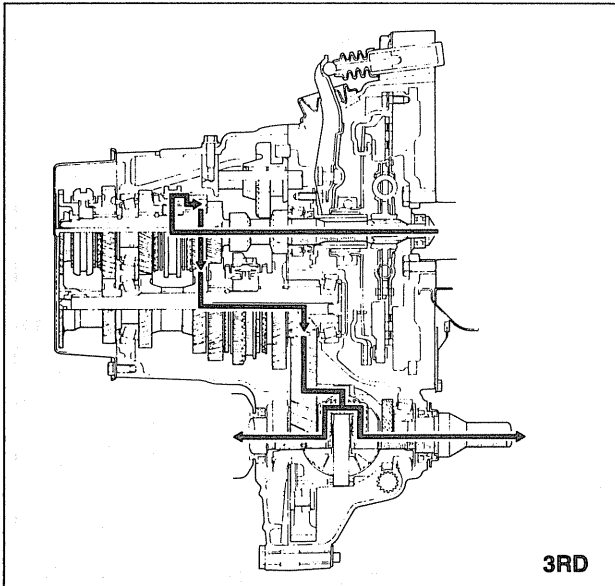
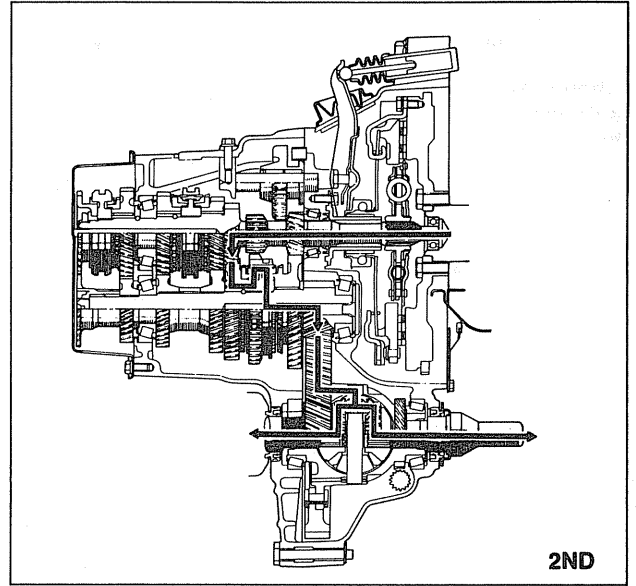
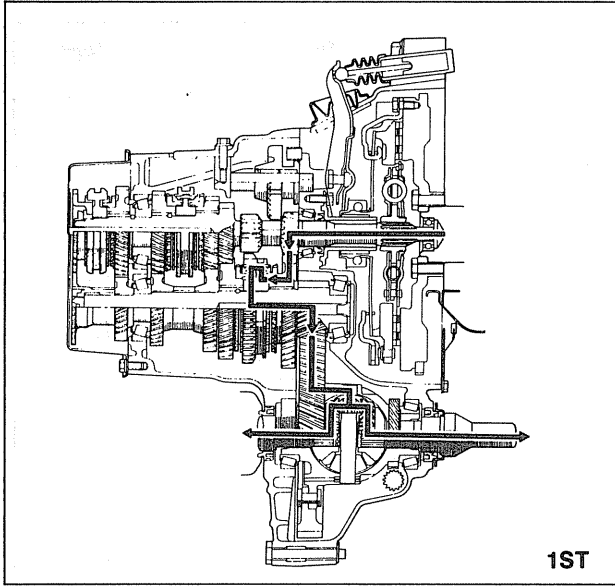

J2

TROUBLESHOOTING GUIDE

Problem	Possible cause	Remedy	Page
Change lever won't shift smoothly, or is hard to shift	Seized change lever ball	Replace	J2-48
	Seized change control rod joint	Replace	J2-48
	Bent change control rod	Replace	J2-48
Too much play in change lever	Worn change control rod bushing	Replace	J2-48
	Weak ball spring or change lever	Replace	J2-48
	Worn ball bushing or change lever	Replace	J2-48
Difficult to shift	Bent change rod	Replace	J2-48
	No grease in transmission control	Lubricate with grease	J2-48
	Insufficient oil	Add oil	J2- 7
	Deterioration of oil quality	Replace with oil of specified quality	J2- 7
	Wear or play of shift fork or shift rod	Replace	J2-12
	Worn synchronizer ring	Replace	J2-24
	Worn synchronizer gear cone	Replace	J2-24
	Bad contact of synchronizer ring and gear cone	Replace	J2-24
	Excessive longitudinal play of gears	Replace	J2-19
	Worn bearing	Adjust or replace	J2-19
	Worn synchronizer key spring	Replace	J2-19
	Excessive primary shaft gear bearing preload	Adjust	J2-34
	Improperly adjusted change guide plate	Adjust	J2-15
	Won't stay in gear	Bent change control rod	Replace
Worn change control rod bushing		Replace	J2-48
Weak change lever ball spring		Replace	J2-48
Improperly installed extension bar		Tighten	J2-48
Worn shift fork		Replace	J2-19
Worn clutch hub		Replace	J2-24
Worn clutch hub sleeve		Replace	J2-25
Worn gear sliding part of both shaft gears		Replace	J2-23
Worn gear sliding part of each gear		Replace	J2-23
Worn steel sliding groove of control end		Replace	J2-12
Weak spring pressing against steel ball		Replace	J2-12
Excessive thrust clearance		Replace	J2-30,31,32
Worn bearing		Replace	J2-19
Improperly installed engine mount	Tighten	J2-43	
Abnormal noise	Insufficient oil	Add oil	J2- 7
	Deterioration of oil quality	Replace	J2- 7
	Worn bearing	Adjust or replace	J2-19
	Worn gear sliding surface of both shaft gears	Replace	J2-19
	Worn sliding surfaces of gears	Replace	J2-19
	Excessive gear backlash	Replace	J2-19
	Damaged gear teeth	Replace with oil of specified quality	J2-23,24
	Foreign material in gears	Replace	J2-19
Damaged differential gear, or excessive backlash	Adjust or replace	J2-27	

16U0J2-025

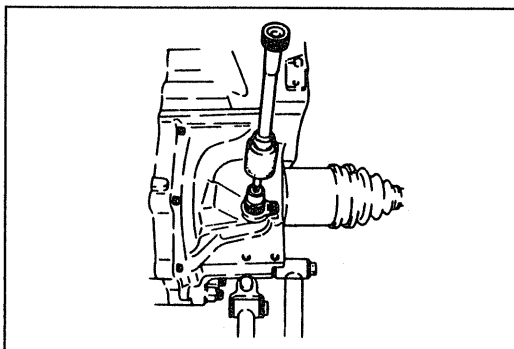

06U0J1-006

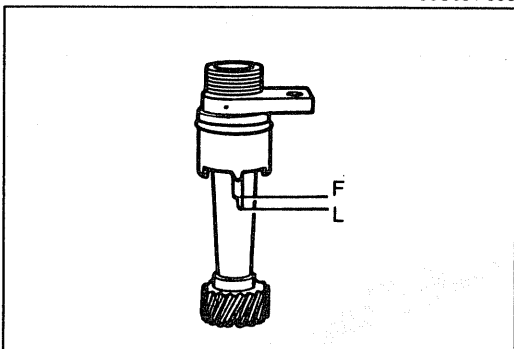

06U0J1-007

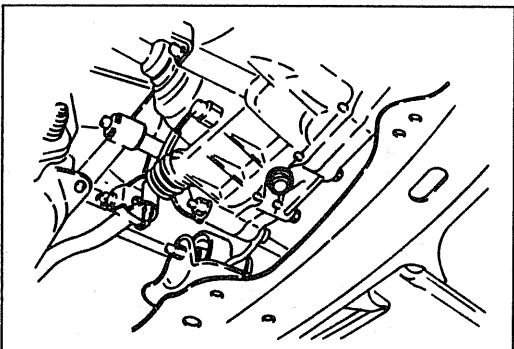

06U0J1-008

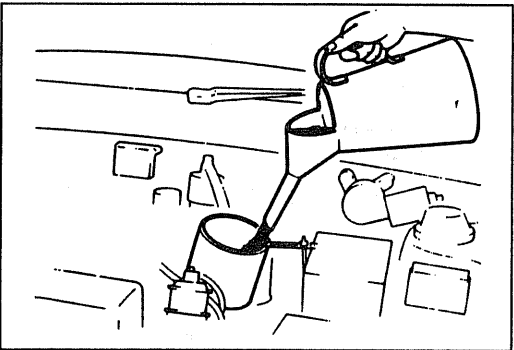

16U0J2-002

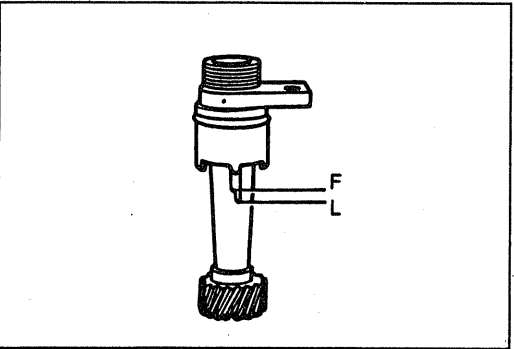

06U0J1-010

TRANSAXLE OIL

INSPECTION

1. Park the vehicle on level ground.
2. Slide up the speedometer cable dust cover, and disconnect the cable from the speedometer driven gear.
3. After removing the bolt, pull the gear case to remove it from the housing. (Insert a flat-tipped screwdriver between the speedometer gear case and the clutch housing, and use it to pry the gear case loose if necessary.)
4. Check that the oil level is between the "F" and "L".
5. If not, add the necessary amount of the specified oil through the gear case hole.
6. Install the speedometer driven gear.

REPLACEMENT

1. Park the vehicle on level ground.
2. Remove the speedometer driven gear. (See "INSPECTION" section above.)
3. Remove the drain plug, and drain the oil.

4. Replace the drain plug, and add the necessary amount of the specified oil through the speedometer gear case hole.

Specified oil

Type

All-season

SAE 75W-90

ATF: DEXRON-II

Above -18°C (0°F):

API: GL-4 or GL-5

SAE 80W-90 or SAE 90

Capacity: 3.65 liters (3.9 US qt, 3.2 Imp qt)







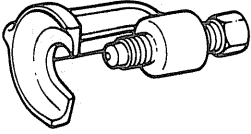
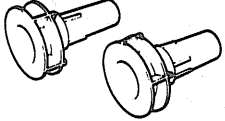
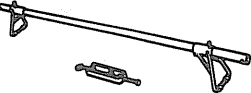
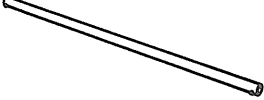
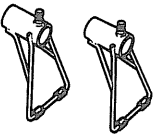
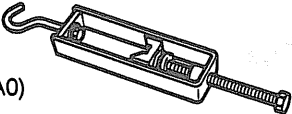
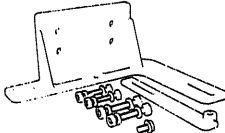
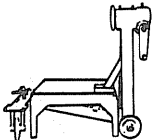
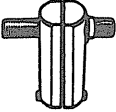
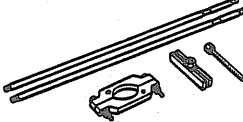
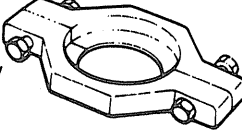
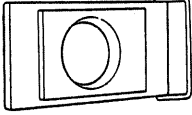
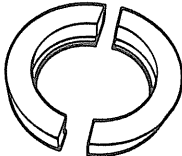
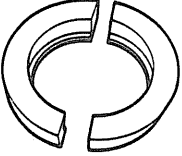
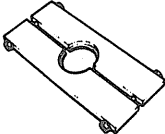
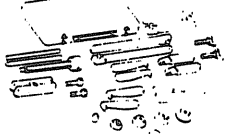

5. Check that the oil level is between the "F" and "L".
6. If not, add the necessary amount of the specified oil through the gear case hole.
7. Install the speedometer driven gear.

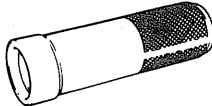
J2

TRANSAXLE

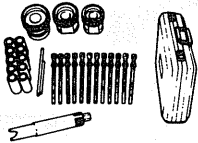
PREPARATION
SST

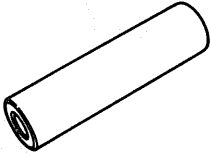
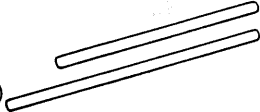
<p>49 0118 850C Puller, ball joint</p> 	<p>For removal of ball joint</p>	<p>49 G027 003 Holder, diff. side gear</p> 	<p>For support of differential side gears</p>
<p>49 G017 5A0 Support, engine</p> 	<p>For support of engine</p>	<p>49 G017 501 Bar (Part of 49 G017 5A0)</p> 	<p>For support of engine</p>
<p>49 G017 502 Support (Part of 49 G017 5A0)</p> 	<p>For support of engine</p>	<p>49 G017 503 Hock (Part of 49 G017 5A0)</p> 	<p>For support of engine</p>
<p>49 G019 0A0 Hanger, transaxle</p> 	<p>For disassembly and assembly of transaxle</p>	<p>49 0107 680A Engine stand</p> 	<p>For disassembly and assembly of transaxle</p>
<p>49 FT01 361 Remover, bearing</p> 	<p>For removal of bearing outer race</p>	<p>49 0187 520 Puller, rear axle shift bearing</p> 	<p>For removal of bearing inner race</p>
<p>49 0636 145 Puller, fan pulley boss</p> 	<p>For removal and installation of bearing inner race</p>	<p>49 F401 366A Plate</p> 	<p>For removal of bearing inner race</p>
<p>49 G017 101 Attachment N</p> 	<p>For removal of bearing inner race</p>	<p>49 G017 203 Attachment P</p> 	<p>For removal of bearing inner race</p>
<p>49 G027 002 Removing plate</p> 	<p>For removal of side bearing inner race</p>	<p>49 0839 425C Puller set, bearing</p> 	<p>For removal of side bearing inner race</p>

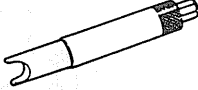
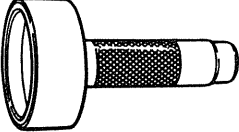
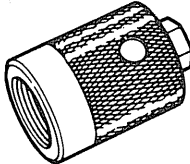
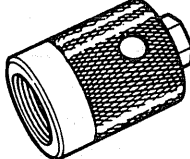
<p>49 G030 338 Attachment E</p> 	<p>For installation of bearing inner race</p>	<p>49 F401 331 Body</p> 	<p>For installation of bearing inner race</p>
<p>49 F401 336B Attachment B</p> 	<p>For installation of bearing inner race</p>	<p>49 F401 337A Attachment C</p> 	<p>For installation of bearing inner race</p>
<p>49 G019 018 Selector for $\phi 72$</p> 	<p>For adjustment of bearing preload (Secondary)</p>	<p>49 G027 001 Selector, $\phi 75$ bearing</p> 	<p>For adjustment of bearing preload (Differential)</p>
<p>49 G030 380C Shim selector set</p> 	<p>For adjustment of bearing preload</p>	<p>49 F401 382A Selector $\phi 52$ (Part of 49 G030 380C)</p> 	<p>For adjustment of bearing preload (Primary)</p>
<p>49 F401 384 Collar (Part of 49 G030 380C)</p> 	<p>For adjustment of bearing preload</p>	<p>49 F401 385 Bar (Part of 49 G030 380C)</p> 	<p>For adjustment of bearing preload</p>
<p>49 G019 021 Bolt set (Part of 49 G030 380C)</p> 	<p>For adjustment of bearing preload</p>	<p>49 FT01 515A Adaptor, preload (Part of 49 G030 380C)</p> 	<p>For adjustment of bearing preload</p>
<p>49 B001 795 Installer, oil seal</p> 	<p>For installation of oil seal</p>	<p>49 B017 102 Adaptor, preload</p> 	<p>For adjustment of preload</p>
<p>49 G017 202 Adaptor, preload</p> 	<p>For adjustment of preload</p>	<p>06U0J2-006</p>	

J2

REMOVAL

1. Disconnect the negative battery cable.
2. Raise the vehicle and support it with safety stands.
3. Drain the transaxle oil into a suitable container.
4. Remove in the order shown in the figure, referring to **Removal Note**.

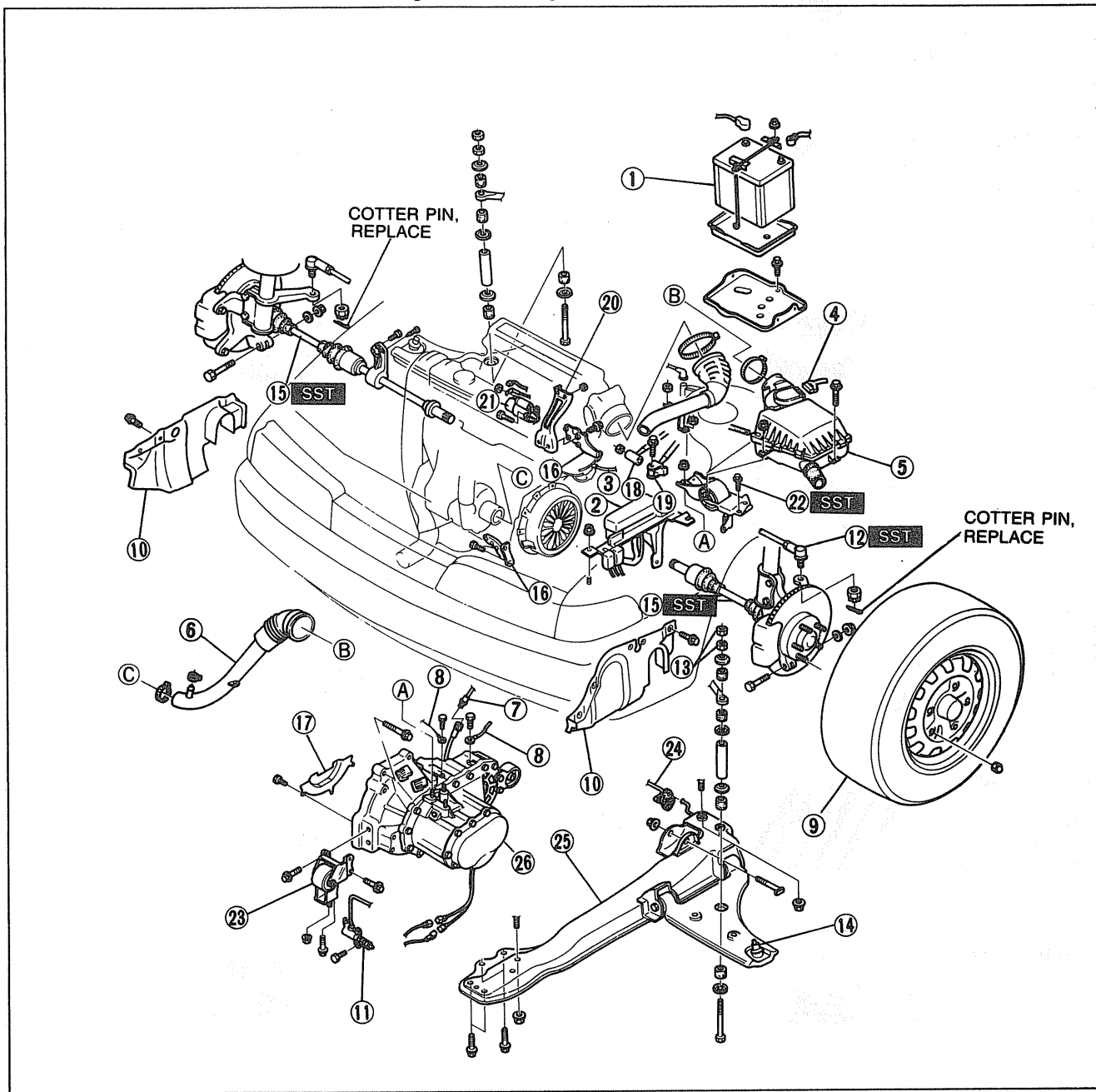

06U0J2-007

- | | | |
|-----------------------------|--------------------------|-----------------------------|
| 1. Battery | 12. Tie-rod end | 21. Starter |
| 2. Main fuse block | Removal page J2-11 | 22. Engine mount No.4 |
| 3. Distributor lead | 13. Nuts (stabilizer) | Removal page J2-11 |
| 4. Air flow meter connector | 14. Lower arm ball-joint | 23. Engine mount No.2 |
| 5. Air cleaner assembly | 15. Driveshaft | 24. Hanger rubber |
| 6. Intercooler hose | Removal page J2-11 | 25. Crossmember |
| 7. Speedometer cable | 16. Gusset plate(s) | 26. Transaxle |
| 8. Ground(s) | 17. Under cover | Removal page J2-11 |
| 9. Wheel(s) | 18. Extension bar | Disassembly ... page J2-12 |
| 10. Splash shield(s) | 19. Control rod | Inspection page J2-23 |
| 11. Clutch release cylinder | 20. Surge tank bracket | Assembly page J2-28 |

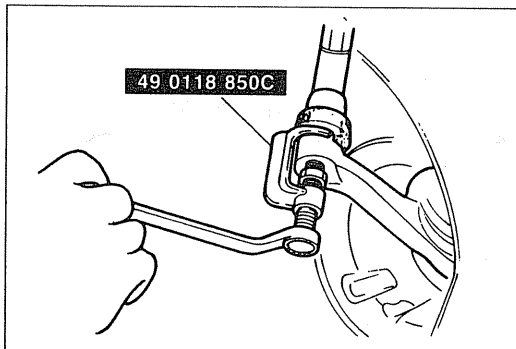

06U0J1-013

Removal note

Tie-rod end

Separate the tie-rod end from the knuckle with the **SST**.

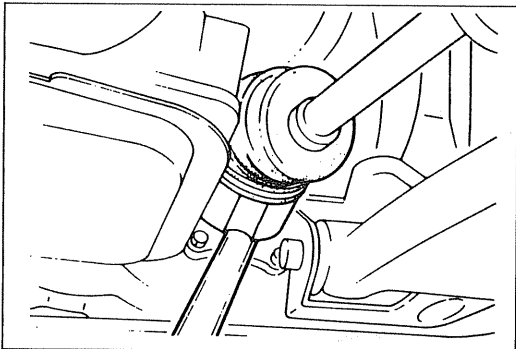

06U0J1-014

Driveshaft

1. Separate the left driveshaft from the transaxle by prying with a bar inserted between the shaft and the case.

Caution

- Do not damage the oil seal.
- Do not separate the driveshaft by pulling the disc plate.

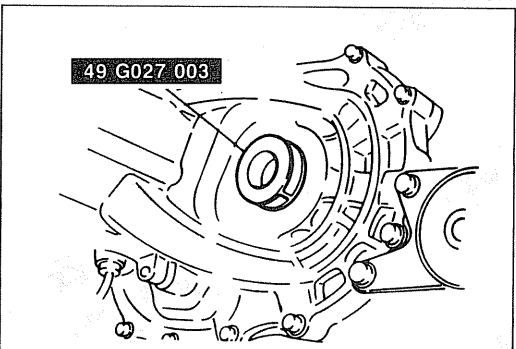

06U0J1-015

2. Install the **SST** to the differential side gear.

Note

- Failure to install the SST may cause the differential side gears to become mispositioned.

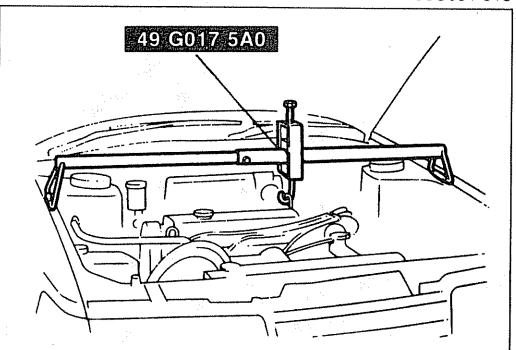

06U0J1-016

Engine mount No.4

Suspend the engine with the **SST**.

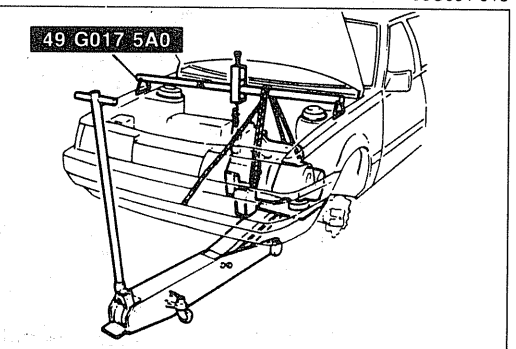

06U0J1-017

Transaxle

1. Lean the engine toward the transaxle.
2. Support the transaxle with a jack.
3. Remove the remaining transaxle mounting bolts.
4. Remove the transaxle.

DISASSEMBLY

Precaution

1. Clean the transaxle exterior thoroughly with steam or cleaning solvents before disassembly.
2. Clean the removed parts with cleaning solvent, and dry with compressed air. (Except sealed bearings.)
Clean out all holes and passages with compressed air, and check that there are no obstructions.
3. Wear eye protection when using compressed air to clean components.

Step 1

1. Disassemble in the order shown in the figure, referring to **Disassembly Note**.

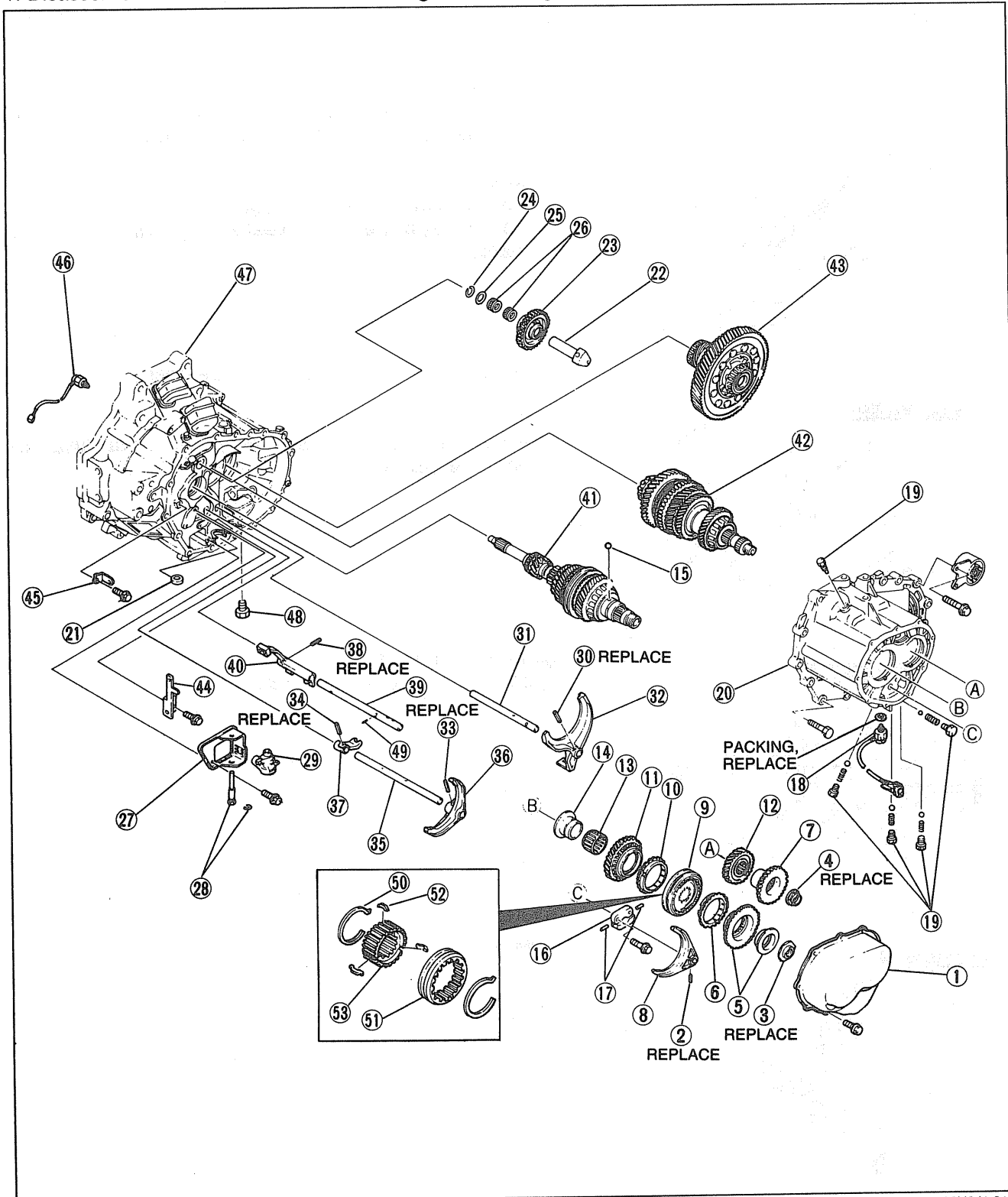

1. Rear cover	15. Ball	36. Shift fork (3rd/4th)
2. Roll pin Removal page J2-13	16. Interlock plate	37. Shift rod end (3rd/4th)
3. Locknut Removal page J2-14	17. Interlock pins	38. Roll pin
4. Locknut	18. Reverse switch	39. Shift rod (5th/Rev.)
5. Primary reverse synchronizer gear and gear sleeve Inspection page J2-23	19. Bolt(s), spring(s) and ball(s) Removal page J2-14	40. Shift rod end (5th/Rev.)
6. Synchronizer ring Inspection page J2-24	20. Transaxle case Removal page J2-13 Disassembly ... page J2-15	41. Primary shaft gear assembly Disassembly ... page J2-19
7. Secondary reverse synchronizer gear Inspection page J2-23	21. Magnet	42. Secondary shaft gear assembly Disassembly ... page J2-19
8. Shift fork (5th/Rev.) Removal page J2-14	22. Reverse idle shaft	43. Differential assembly Disassembly ... page J2-21
9. Clutch hub assembly (5th/Rev.)	23. Reverse idle gear Inspection page J2-25	44. Reverse shift lever
10. Synchronizer ring Inspection page J2-24	24. Snap ring	45. Lever set spring
11. 5th gear Inspection page J2-23	25. Washer	46. Neutral switch
12. Secondary 5th gear Inspection page J2-23	26. Needle bearings	47. Clutch housing Disassembly ... page J2-15
13. Needle bearing	27. Base plate unit	48. Drain plug
14. Gear sleeve	28. Crank lever shaft and snap ring	49. Interlock pin
	29. Crank lever assembly	50. Synchronizer key spring
	30. Roll pin	51. Clutch hub sleeve Inspection page J2-25
	31. Shift rod (1st/2nd)	52. Synchronizer key
	32. Shift fork (1st/2nd)	53. Clutch hub Inspection page J2-24
	33. Roll pin	
	34. Roll pin	
	35. Shift rod (3rd/4th)	

06U0J2-008

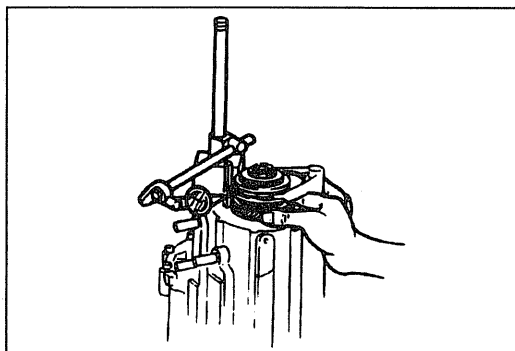

16U0J2-003

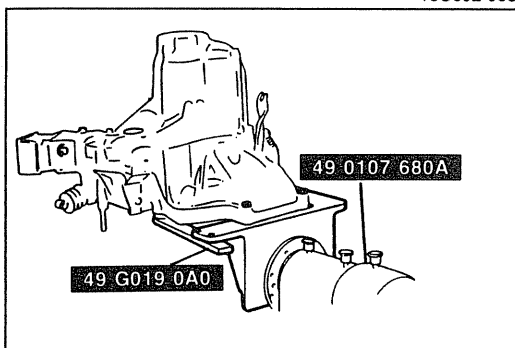

86U07A-037

Preinspection

5th gear thrust clearance

1. Measure the 5th gear thrust clearance with a dial indicator.

Clearance: 0.150—0.262mm (0.0059—0.0103 in)

Maximum: 0.262mm (0.0103 in)

2. If the clearance exceeds the maximum, check the contact surfaces of 5th gear and the clutch hub. Replace worn or damaged parts.

Disassembly note

Transaxle

Mount the transaxle on the **SST**.

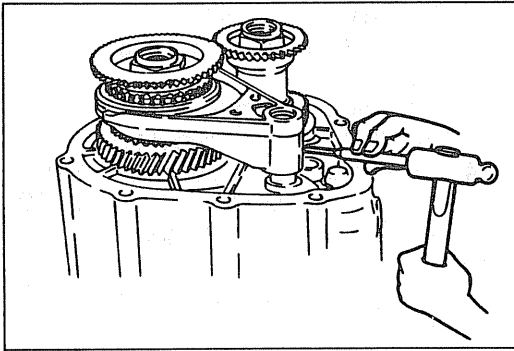

16U0J2-004

Roll pin

Remove the roll pin with pin punch.

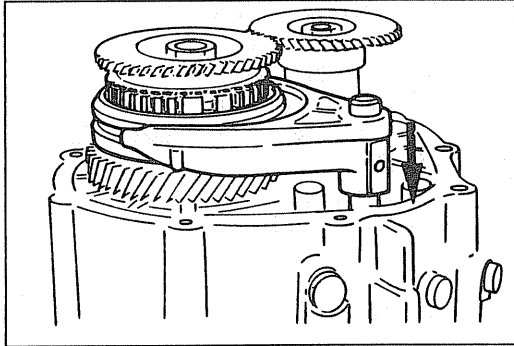

86U07A-123

Locknut

1. After removing the roll pin, shift the gears to 5th gear.
2. Shift the gears to 1st gear.
3. Remove the locknuts.

Caution

- Uncrimp the tab of the locknuts.

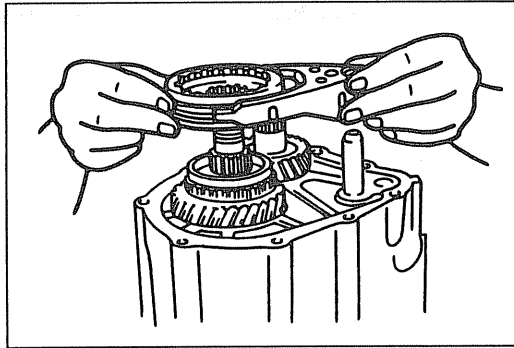

76U07A-040

Shift Fork (5th)

Remove the shift fork (5th) together with the clutch hub assembly.

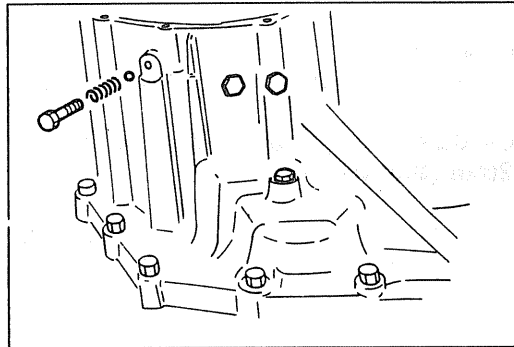

96U07A-022

Bolts, Springs and Balls

1. Remove the bolts, springs and balls.
2. Remove the transaxle case installation bolts, and remove the transaxle case.

Step 2

1. Disassemble in the order shown in the figure, referring to **Disassembly Note**.

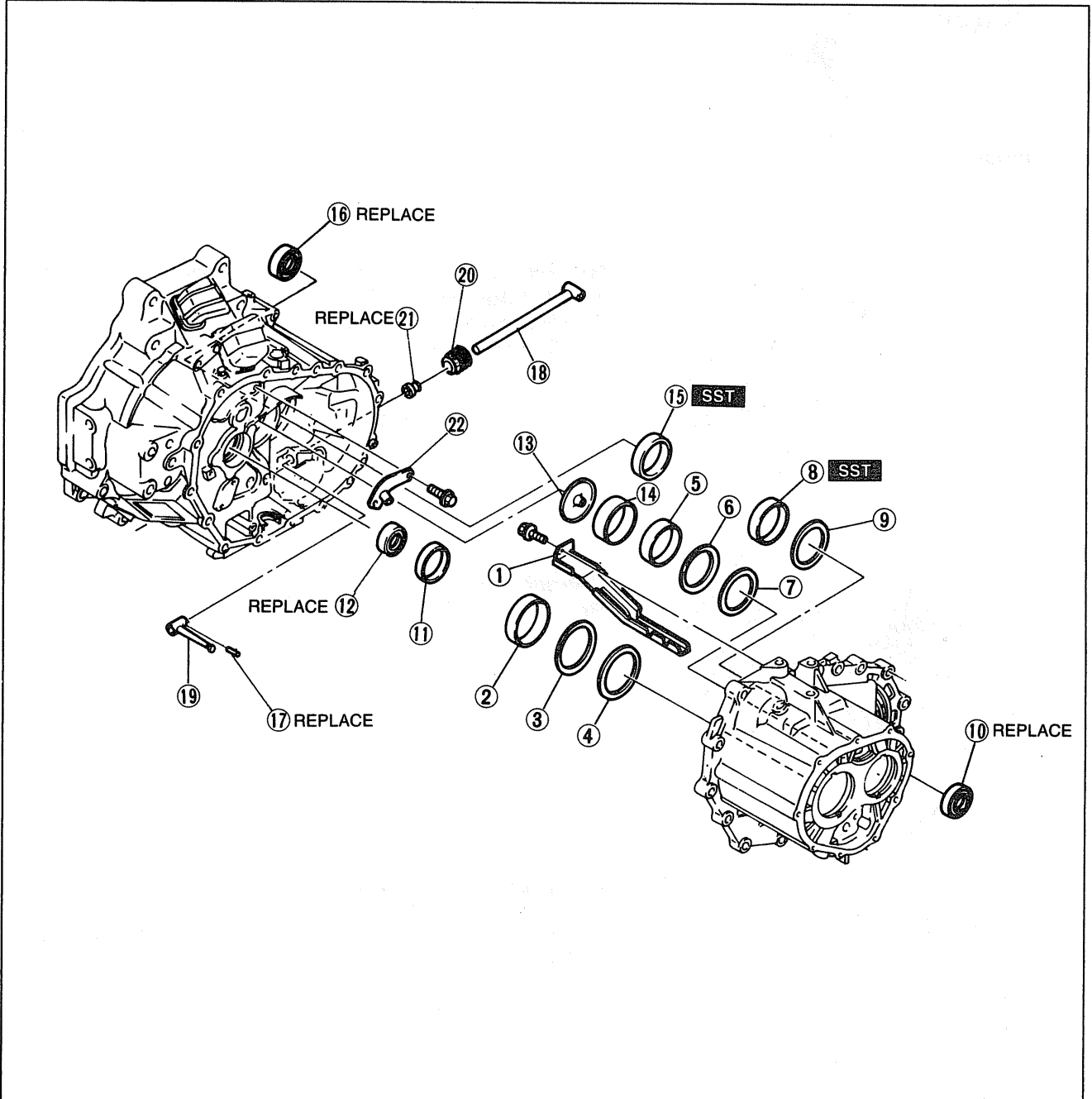

16U0J2-005

- | | | |
|---|--|--|
| 1. Oil passage | 10. Oil seal
Do not remove if not
necessary
Replacement
(On-vehicle) .. page J2-16 | 16. Oil seal
Do not remove if not
necessary
Replacement
(On-vehicle) .. page J2-16 |
| 2. Bearing outer race | 11. Bearing outer race | 17. Roll pin
Removal page J2-16 |
| 3. Diaphragm spring | 12. Oil seal | 18. Change rod
Removal page J2-16 |
| 4. Adjust shim | 13. Funnel | 19. Change arm |
| 5. Bearing outer race | 14. Bearing outer race
Removal page J2-16 | 20. Boot |
| 6. Diaphragm spring | 15. Bearing outer race
Removal page J2-16 | 21. Oil seal |
| 7. Adjust shim | | 22. Baffle plate |
| 8. Bearing outer race
Removal page J2-16 | | |
| 9. Adjust shim | | |

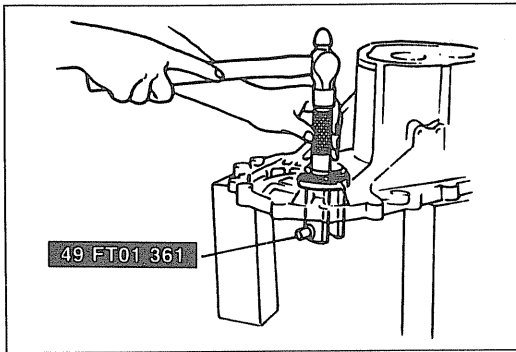

86U07A-126

Disassembly note

Bearing outer race (differential)

Remove the bearing outer races with the **SST**.

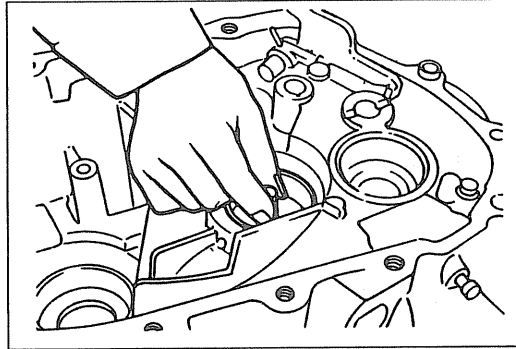

86U07A-127

Bearing outer race and funnel (secondary shaft gear; clutch housing)

Remove the bearing outer race by lifting the funnel and the race out together.

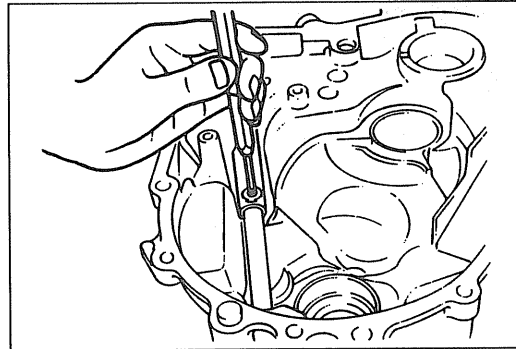

86U07A-129

Change rod

Remove the roll pin with pin punch.

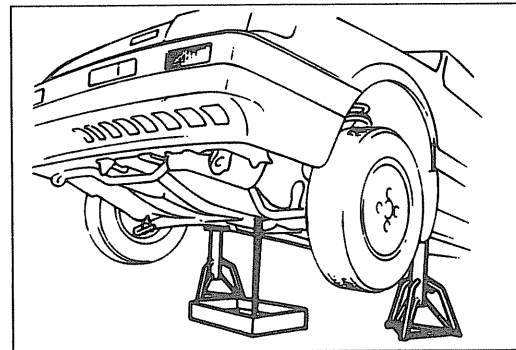

06U0J1-023

On-vehicle replacement

Oil seals

Jack up the vehicle, support it on safety stands, and then drain the transaxle oil. Next, use the following procedure to replace the driveshaft oil seals:

1. Remove the front wheel(s).
2. Remove the splash shield(s).
3. Separate the front stabilizer from the lower arm.

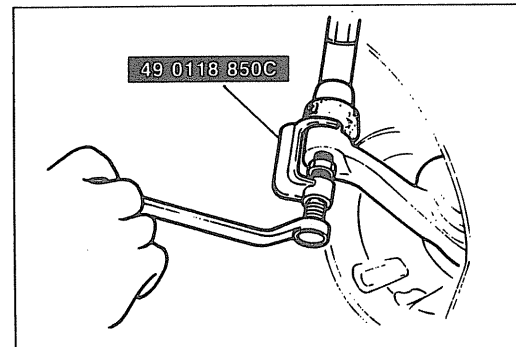

86U07A-009

4. Remove the clinch bolt and pull the lower arm downward. Separate the knuckle from the lower arm ball-joint.

Note

- Be careful not to damage the ball-joint dust boot.

5. Remove the cotter pin then disconnect the tie-rod end with the **SST**.

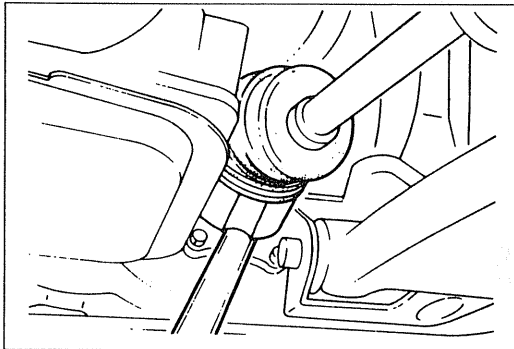

06U0J1-024

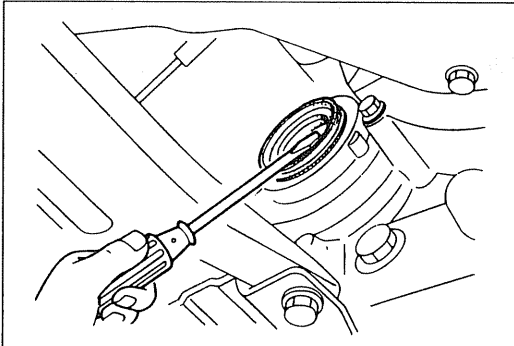

86U07A-011

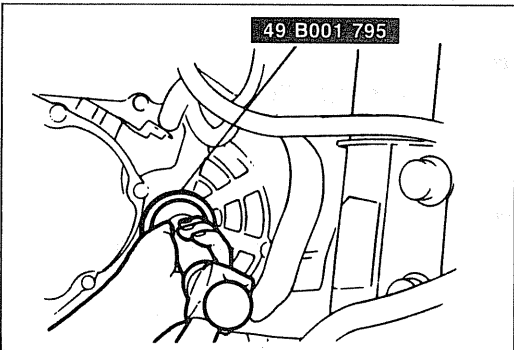

86U07A-012

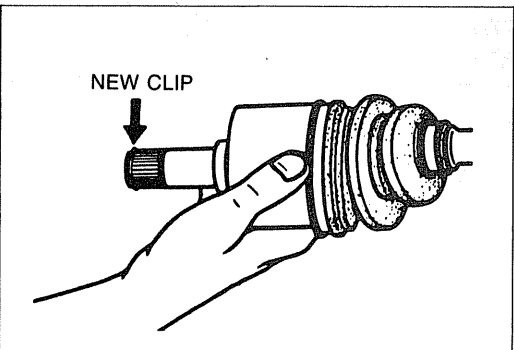

86U07A-013

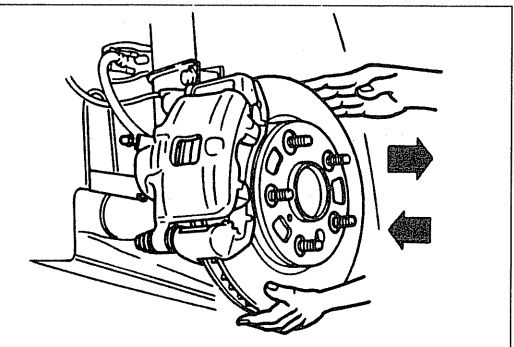

86U07A-014

Caution

- Do not damage the oil seal.
- Do not separate the driveshaft by pulling the disc plate.

6. Separate the left driveshaft from the transaxle by prying with a bar inserted between the shaft and the case.

7. Remove the oil seal with a flat-tipped screwdriver.

8. Tap the new oil seal into the transaxle case with the **SST**.

Note

- Tap in until the oil seal installer contacts the case.
- Coat the oil seal lip with transaxle oil.

9. Replace the driveshaft end clip with a new one. Insert the clip with the gap at the top of the groove.

10. Install the driveshaft as follows:

- (1) Pull the front hub outward, then fit the driveshaft into the transaxle.
- (2) Insert the driveshaft into the transaxle by pushing on the wheel hub assembly.

Note

- Be careful not to damage the oil seal.
- After installation is finished, pull the front hub slowly outward to check that the driveshaft is held securely by the clip.

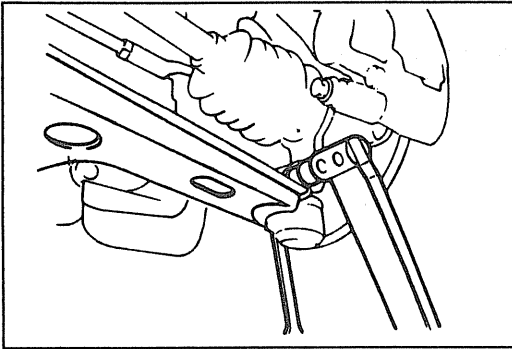

86U07A-015

11. Install the lower arm ball-joint to the knuckle, and tighten the clinch bolt.

Tightening torque:

43—54 N-m (4.4—5.5 m-kg, 32—40 ft-lb)

12. Install the tie-rod end and new cotter pin.

Tightening torque:

29—44 N-m (3.0—4.5 m-kg, 22—33 ft-lb)

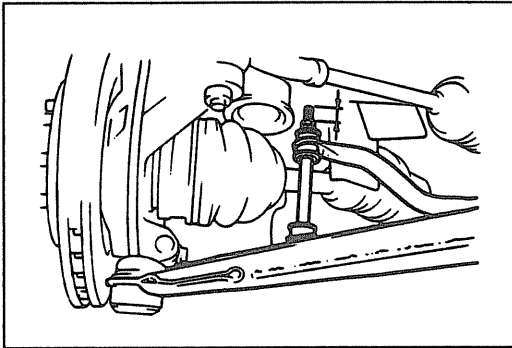

06U0J2-060

13. Adjust and tighten the stabilizer.

Tightening torque:

16—23 N-m (1.6—2.3 m-kg, 12—17 ft-lb)

Dimension: 20.1 ± 2mm (0.79 ± 0.08 in)

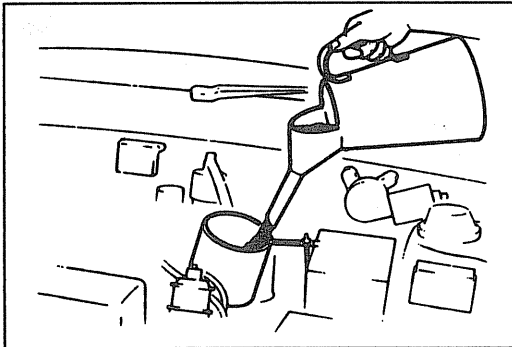

16U0J2-006

14. Install the drain plug.

Tightening torque:

39—59 N-m (4.0—6.0 m-kg, 29—43 ft-lb)

15. Install the wheel.

Tightening torque:

88—118 N-m (9.0—12.0 m-kg, 65—87 ft-lb)

16. Add the correct quantity of the specified oil.

Type:

All-season SAE 75W-90 ATF: DEXRON-II

Above -18°C (0°F):

API: GL-4 or GL-5

SAE 80W-90 or SAE 90

Capacity: 3.65 liters (3.9 US qt, 3.2 Imp qt)

Step 3

1. Disassemble in the order shown in the figure, referring to **Disassembly Note**.

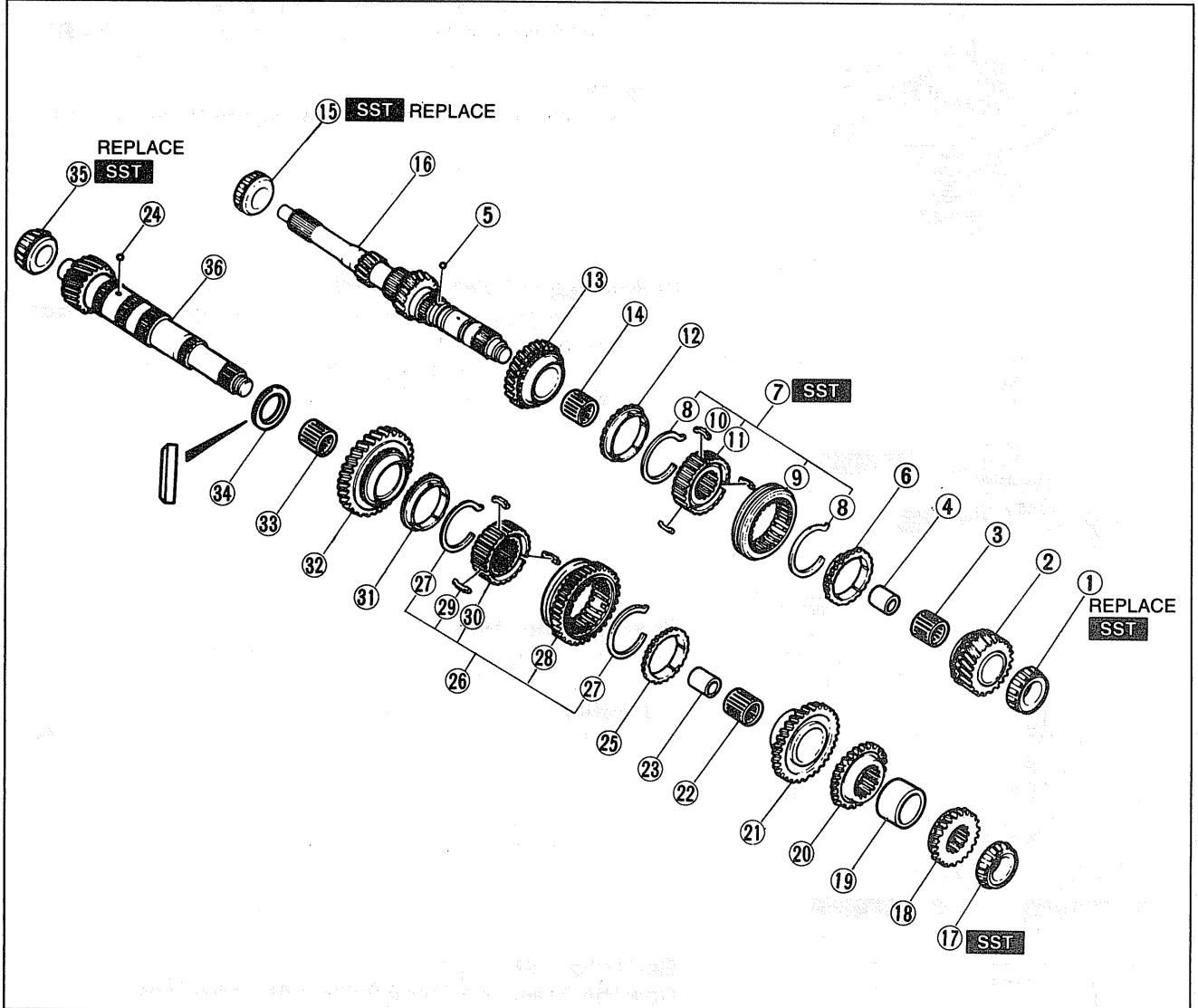

16U0J2-007

- | | | |
|--|---|---|
| 1. Bearing inner race
Removal page J2-20 | 13. Primary 3rd gear
Inspection page J2-23 | 25. Synchronizer ring
Inspection page J2-24 |
| 2. Primary 4th gear
Inspection page J2-23 | 14. Needle bearing | 26. Clutch hub assembly (1st/2nd)
Removal page J2-20 |
| 3. Needle bearing | 15. Bearing inner race
Removal page J2-20 | 27. Synchronizer key spring |
| 4. Gear sleeve | 16. Primary shaft
Inspection page J2-23 | 28. Clutch hub sleeve |
| 5. Ball | 17. Bearing inner race
Removal page J2-20 | 29. Synchronizer key |
| 6. Synchronizer ring
Inspection page J2-24 | 18. Secondary 4th gear
Inspection page J2-23 | 30. Clutch hub
Inspection page J2-24 |
| 7. Clutch hub assembly (3rd/4th)
Removal page J2-20 | 19. Gear sleeve | 31. Synchronizer ring
Inspection page J2-24 |
| 8. Synchronizer key spring | 20. Secondary 3rd gear
Inspection page J2-23 | 32. Primary 1st gear
Removal page J2-20 |
| 9. Clutch hub sleeve
Inspection page J2-25 | 21. Primary 2nd gear
Inspection page J2-23 | Inspection page J2-23 |
| 10. Synchronizer key | 22. Needle bearing | 33. Needle bearing |
| 11. Clutch hub
Inspection page J2-24 | 23. Gear sleeve | 34. Thrust washer |
| 12. Synchronizer ring
Inspection page J2-24 | 24. Ball | 35. Bearing inner race
Removal page J2-21 |
| | | 36. Secondary shaft
Inspection page J2-23 |

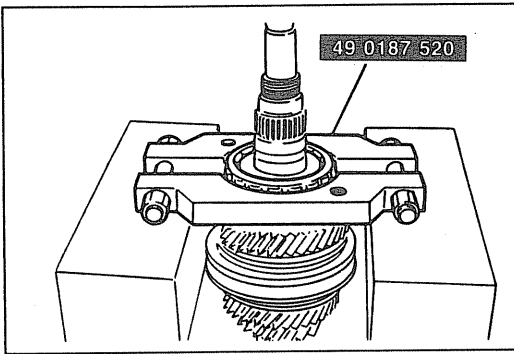

06U0J2-013

Disassembly note
Primary shaft gear
Bearing inner race (primary 4th gear end)
 Remove the bearing inner race and 4th gear with the SST.

Caution
 • Hold the shaft with one hand so that it does not fall.

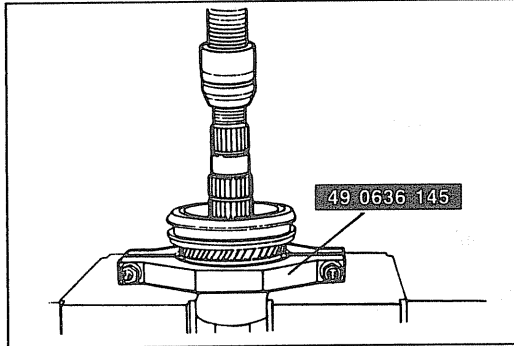

86U07A-132

Clutch hub assembly (3rd/4th)
 Remove the 3rd gear and clutch hub assembly with the SST.

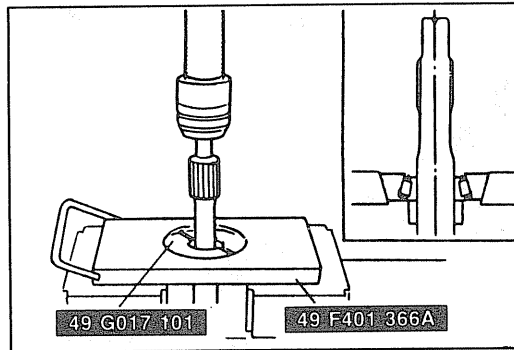

06U0J2-014

Bearing inner race
 Remove the bearing inner race with the SST.

Caution
 • Hold the shaft with one hand so that it does not fall.

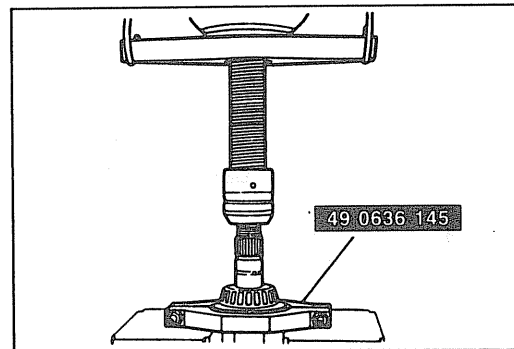

06U0J2-015

Secondary shaft gear
Bearing inner race (secondary 4th gear end)
 Remove the bearing and secondary 4th gear with the SST.

Caution
 • Hold the shaft with one hand so that it does not fall.

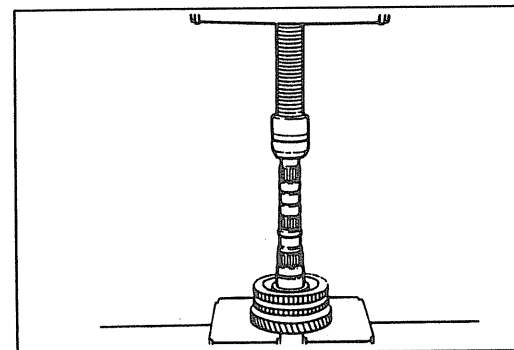

06U0J2-016

Clutch hub assembly and primary 1st gear
 Remove the clutch hub assembly (1st/2nd) and 1st gear.

Caution
 • Hold the shaft with one hand so that it does not fall.

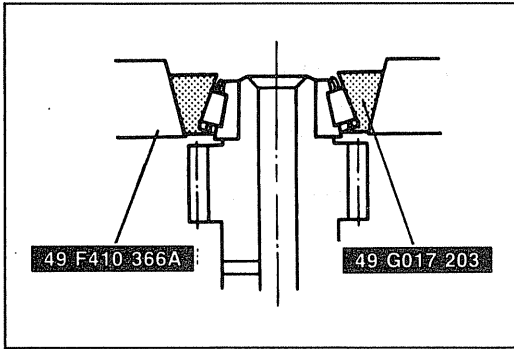

06U0J2-017

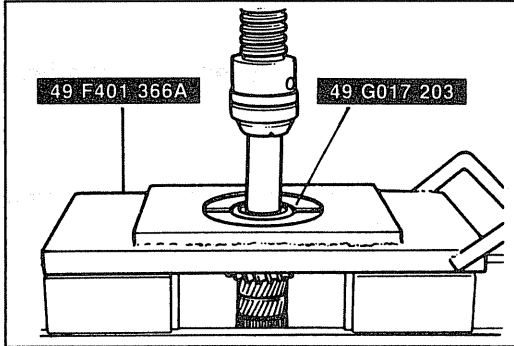

86U07A-137

Bearing inner race

1. Set the **SST** to the bearing inner race as shown.

2. Remove the bearing inner race with the **SST**.

Caution

- Hold the shaft with one hand so that it does not fall.

Step 4 (Differential)

1. Inspect side gears and pinion gears for backlash, referring to **Preinspection**.

Caution

- Do not remove inner races if not necessary.

2. Disassemble in the order shown in the figure, referring to **Disassembly Note**.

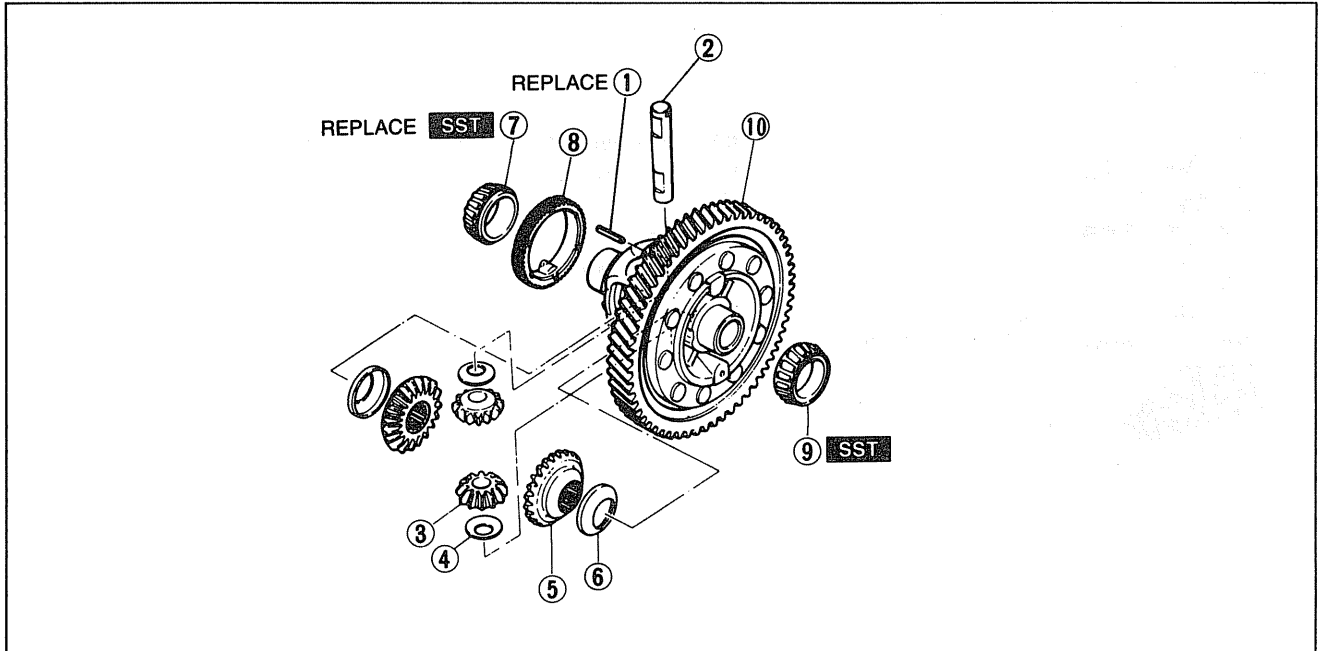

16U0J2-008

- | | | |
|---|--|--|
| 1. Roll pin
Removal page J2-22 | 4. Thrust washer | 8. Speedometer drive gear
Inspection page J2-25 |
| 2. Pinion shaft | 5. Side gear | 9. Side bearing inner race
Removal page J2-22 |
| 3. Pinion gear | 6. Thrust washer | 10. Gear case |
| | 7. Side bearing inner race
Removal page J2-22 | |

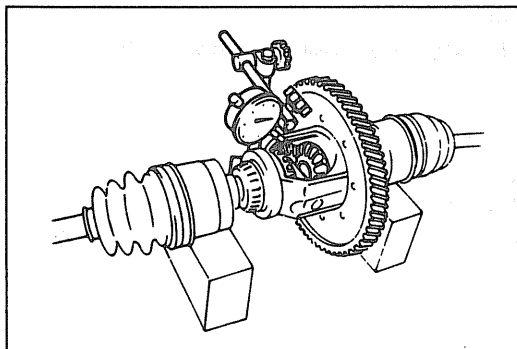

06U0J2-019

Preinspection

Backlash

Before disassembly, check the backlash of the side gears and pinion gears. (Refer to page J2-27.)
If not, repair or replace as necessary.

Standard backlash: 0—0.1mm (0—0.004 in)

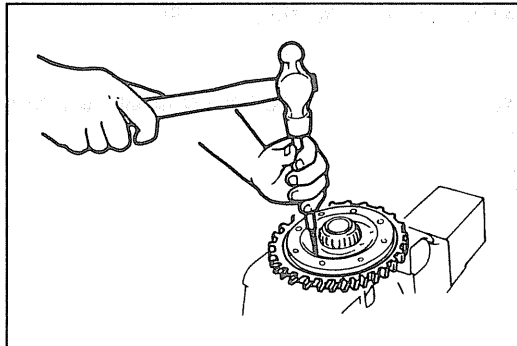

16U0J2-009

Disassembly note

Roll pin

To remove the roll pin from the pinion shaft, place the gear case in a vise and knock the pin out.

Note

- Insert the rod into the roll pin hole from the ring gear mounting surface side.

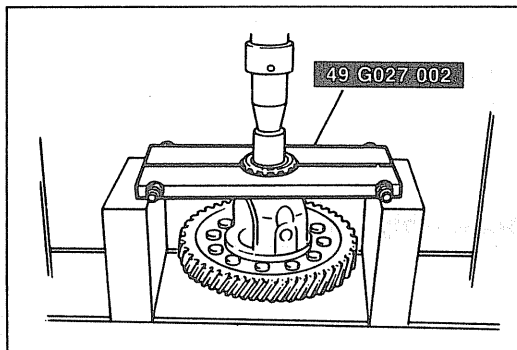

86U07A-140

Side bearing inner race (side opposite ring gear)

Remove the bearing inner race with the SST.

Caution

- Hold the gear case with one hand so that it does not fall.

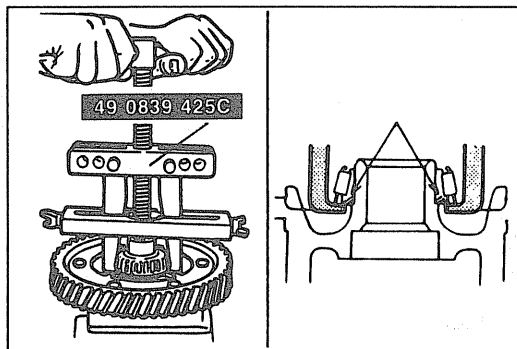

86U07A-141

Side bearing inner race (ring gear side)

Remove the bearing inner race with the SST.

Note

- Use pads in the vise.

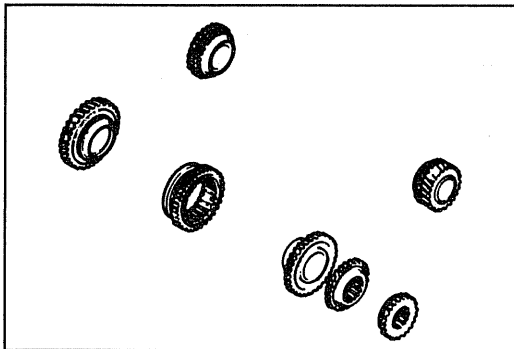

06U0J2-020

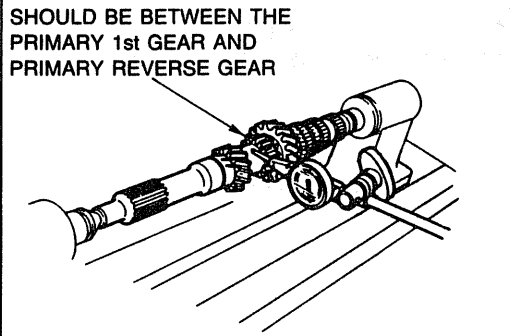

SHOULD BE BETWEEN THE PRIMARY 1st GEAR AND PRIMARY REVERSE GEAR

16U0J2-026

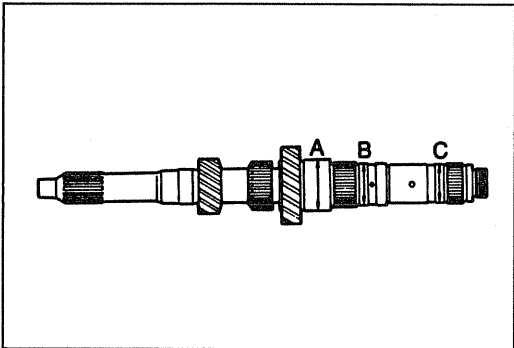

16U0J2-027

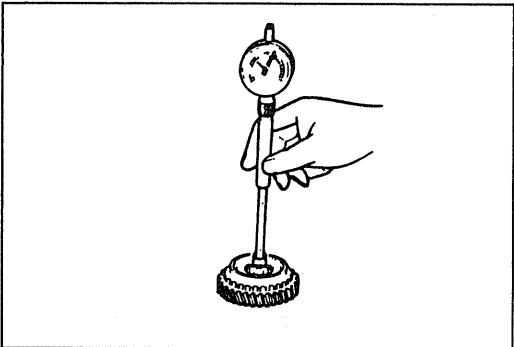

86U07A-144

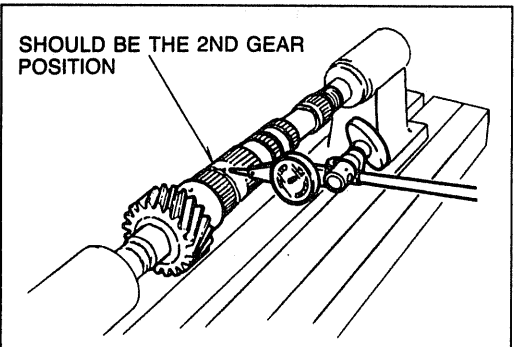

SHOULD BE THE 2ND GEAR POSITION

06U0J2-022

INSPECTION

Check the following parts, replace if necessary.

1st, 2nd, 3rd, 4th, and 5th gears

1. Worn or damaged synchronizer cone.
2. Worn or damaged hub sleeve coupling.
3. Worn or damaged teeth.
4. Worn or damaged inner surface or end surface of gears.

Primary Shaft Gear and Primary Gear

1. Worn or damaged gear contact surface.
2. Worn or damaged splines.
3. Worn teeth.
4. Clogged oil passage.
5. Primary shaft gear run-out.

Run-out: 0.200mm (0.0079 in) max.

Note

- If the shaft gear is replaced, adjust the bearing preload. (Refer to page J2-34.)

Outer diameter:

- A. 41.975—41.991mm (1.6526—1.6532 in)
- B. 34.975—35.000mm (1.3770—1.3780 in)
- C. 31.675—31.700mm (1.2470—1.2480 in)

Inner diameter (gears):

- 3rd. 47.00—47.02mm (1.850—1.851 in)
- 4th. 47.00—47.02mm (1.850—1.851 in)
- 5th. 43.00—43.02mm (1.693—1.694 in)

Secondary Shaft Gear

1. Worn or damaged gear contact surface.
2. Worn or damaged splines.
3. Worn teeth.
4. Clogged oil passage.
5. Secondary shaft gear run-out.

Run-out: 0.03mm (0.0012 in) max.

Note

- If the shaft gear is replaced, adjust the bearing preload. (Refer to page J2-34.)

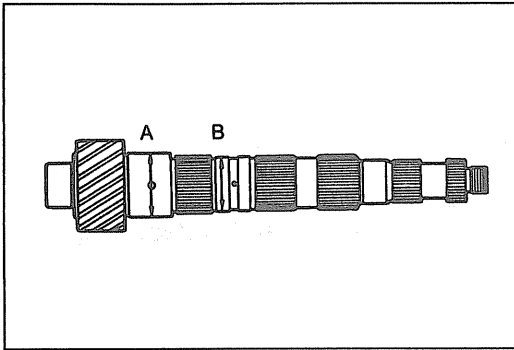

16U0J2-028

Outer diameter:

A. 42.975—42.991mm (1.6919—1.6926 in)

B. 37.175—37.191mm (1.4636—1.4642 in)

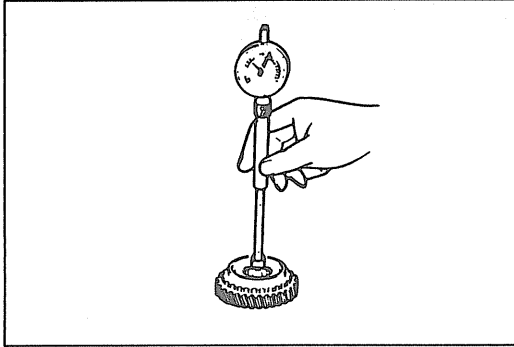

16U0J2-010

Inner diameter (gears):

1st. 48.00—48.02mm (1.890—1.891 in)

2nd. 50.00—50.02mm (1.969—1.969 in)

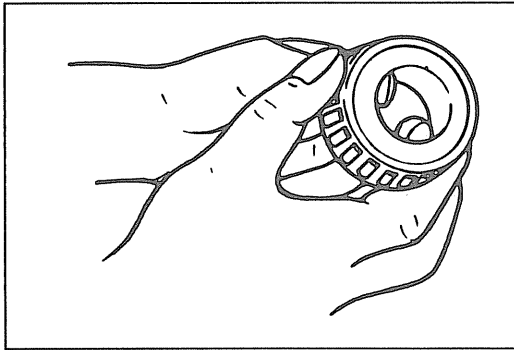

63G07C-122

Bearing

1. Roughness or noise while turning.
2. Damaged bearing
3. Worn bearing.

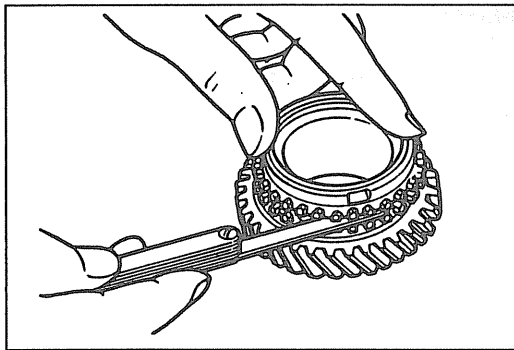

16U0J2-011

Synchronizer Ring

1. Engagement with gear.
2. Worn or damaged teeth.
3. Worn or damaged tapered surface.
4. Clearance from the side of gear.

Clearance: 1.5mm (0.059 in)

Minimum : 0.8mm (0.032 in)

Note

- Place the synchronizer ring on the gear cone and rotate until it stops (approx. 10 to 20 degrees), then measure around the circumference.
- If the clearance is less than specified replace the synchronizer ring or gear.

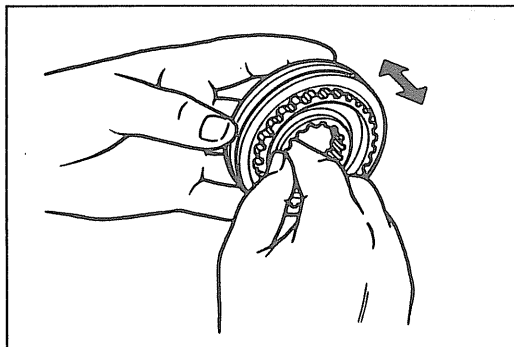

61G07X-183

Clutch Hub

1. Worn or damaged splines.
2. Worn or damaged synchronizer key groove.
3. Worn end surface.
4. Operation of the hub sleeve when installed.

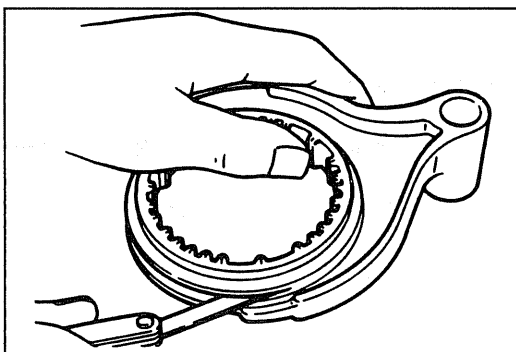

96U07A-029

Clutch Hub Sleeve

1. Worn or damaged hub splines.
2. Worn or damaged sleeve fork groove.
3. Clearance between sleeve and shift fork.

Clearance

mm (in)

	Standard	Maximum
1st/2nd	0.05—0.408 (0.002—0.016)	0.458 (0.018)
3rd/4th	0.1—0.408 (0.004—0.016)	
5th/Rev.		

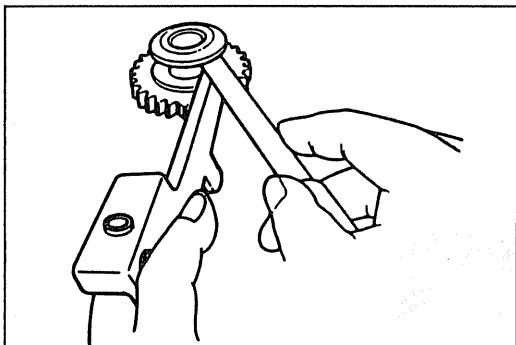

16U0J2-012

Reverse Idle Gear

1. Worn or damaged bushing.
2. Worn or damaged teeth.
3. Worn or damaged reverse shift lever coupling groove.
4. Clearance between sleeve and reverse shift lever.

Clearance: 0.095—0.318mm (0.004—0.013 in)
Maximum: 0.368mm (0.015 in)

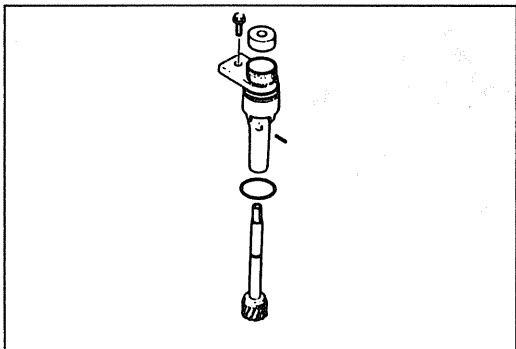

06U0J2-023

Speedometer Driven Gear Assembly

Worn or damaged teeth.

Speedometer Drive Gear

Worn or damaged teeth.

ASSEMBLY

Precaution

1. All O-rings and gasket must be replaced with the new ones included in the overhaul kit.
2. Before assembly, make sure all parts are completely clean.
3. Assemble the parts within 10 minutes after applying sealant. Allow all sealant to cure at least 30 minutes after assembly before filling the transaxle with transaxle oil.
4. If the clutch housing or transaxle case is replaced, adjust the bearing preload of the shaft gears and the preload of the differential side bearings.
5. If the bearing inner races are replaced, assemble new bearing outer races.

Step 1 (Differential)

Assemble in the order shown in the figure, referring to **Assembly Note**.

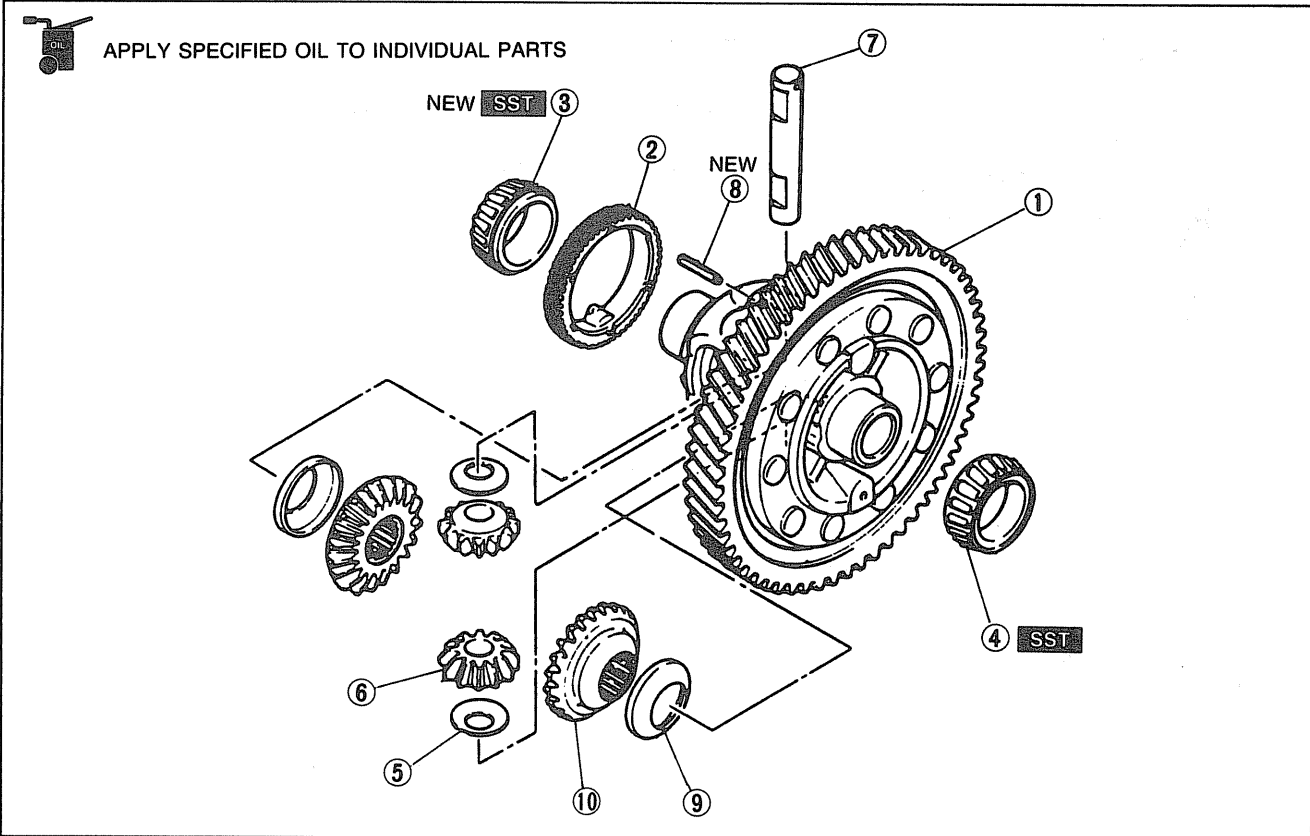

16U0J2-013

- | | |
|-------------------------------|-------------------------------|
| 1. Gear case | 6. Pinion gear |
| 2. Speedometer drive gear | 7. Pinion shaft |
| 3. Side bearing inner race | 8. Roll pin |
| Installation page J2-26 | Installation page J2-27 |
| 4. Side bearing inner race | 9. Thrust washer |
| Installation page J2-27 | 10. Side gear |
| 5. Thrust washer | Installation page J2-27 |

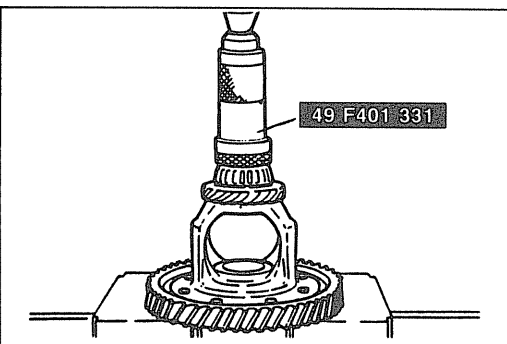

06U0J2-025

Assembly note

Side bearing inner race

1. Install the speedometer drive gear.
2. Install the new side bearing inner race with the **SST**.

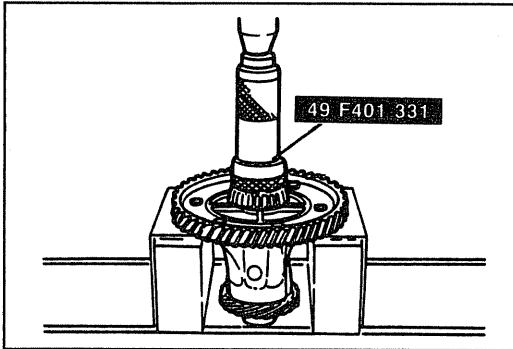

06U0J2-026

Side bearing inner race

Install the bearing inner race with the **SST**.

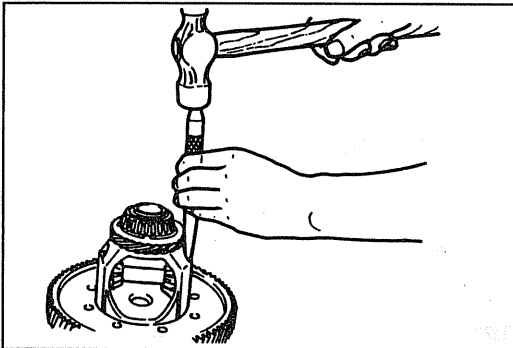

16U0J2-014

Roll pin

1. Install the pinion gears and washers.
2. Install the pinion shaft.
3. After installing the roll pin, make a crimp so that the pin cannot come out of the gear case.

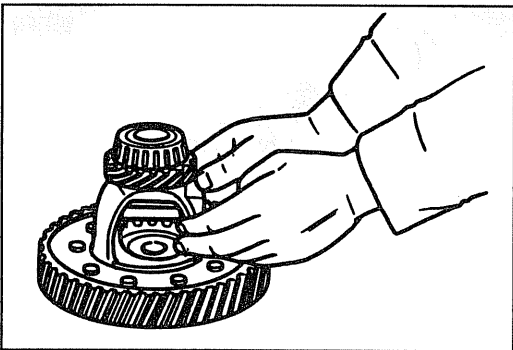

06U0J2-028

Side gears

Install the side gears and washers.

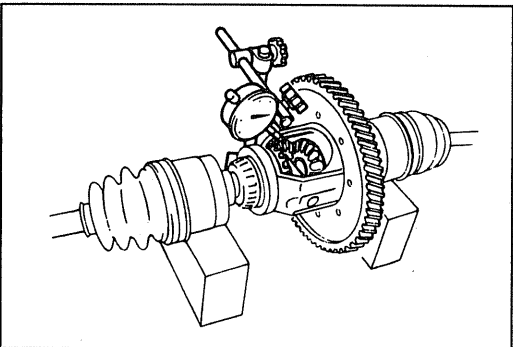

96U07A-034

Backlash of side gear and pinion gear

Check and adjust by the following procedure.

1. Install the left and right driveshafts in the differential assembly.
2. Support the driveshafts on V-blocks as shown in the figure.
3. Measure the backlash of both pinion gears.
4. If not, replace the differential assembly.

Backlash: 0—0.1mm (0—0.004 in)

Step 2

1. Assemble in the order shown in the figure, referring to **Assembly Note**.

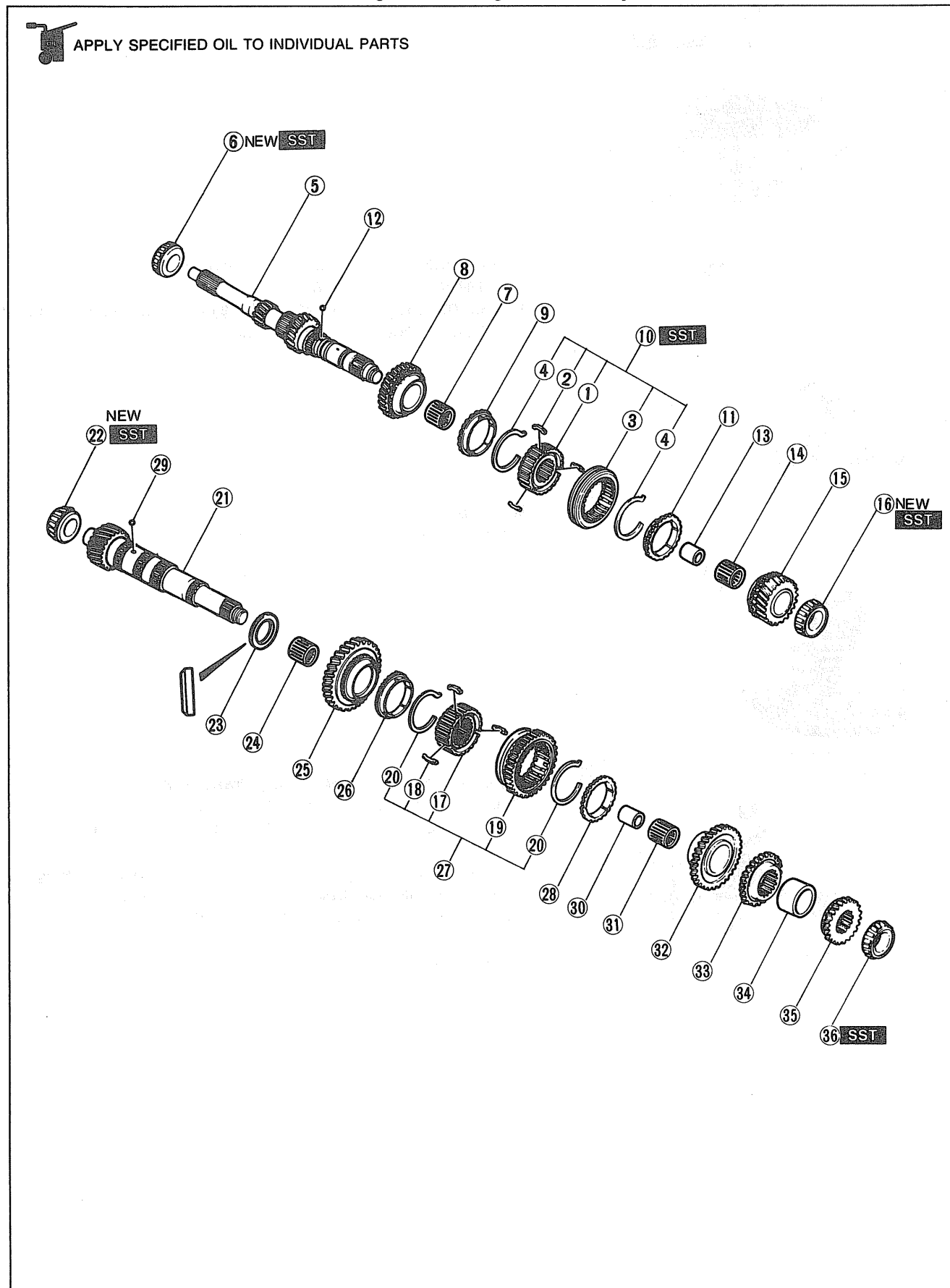

- | | | |
|---|--|---|
| 1. Clutch hub
Installation..... page J2-29 | 13. Gear sleeve | 26. Synchronizer ring
Installation..... page J2-31 |
| 2. Synchronizer key
Installation..... page J2-29 | 14. Needle bearing | 27. Clutch hub assembly (1st/2nd)
Installation..... page J2-31 |
| 3. Clutch hub sleeve | 15. Primary 4th gear
Installation..... page J2-30 | 28. Synchronizer ring |
| 4. Synchronizer key spring | 16. Bearing inner race
Installation..... page J2-30 | 29. Ball |
| 5. Primary shaft | 17. Clutch hub
Installation..... page J2-29 | 30. Gear sleeve |
| 6. Bearing inner race
Installation..... page J2-30 | 18. Synchronizer key
Installation..... page J2-29 | 31. Needle bearing |
| 7. Needle bearing | 19. Clutch hub sleeve | 32. Secondary 2nd gear |
| 8. Primary 3rd gear
Installation..... page J2-30 | 20. Synchronizer key spring | 33. Secondary 3rd gear
Installation..... page J2-31 |
| 9. Synchronizer ring
Installation..... page J2-30 | 21. Secondary shaft | 34. Gear sleeve |
| 10. Clutch hub assembly (3rd/4th)
Installation..... page J2-30 | 22. Bearing inner race
Installation..... page J2-31 | 35. Secondary 4th gear
Installation..... page J2-31 |
| 11. Synchronizer ring
Installation..... page J2-30 | 23. Thrust washer | 36. Bearing inner race
Installation..... page J2-31 |
| 12. Ball | 24. Needle bearing | |
| | 25. Secondary 1st gear
Installation..... page J2-31 | |

16U0J2-015

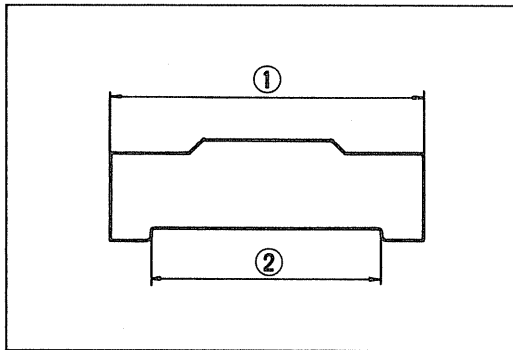

06U0J2-030

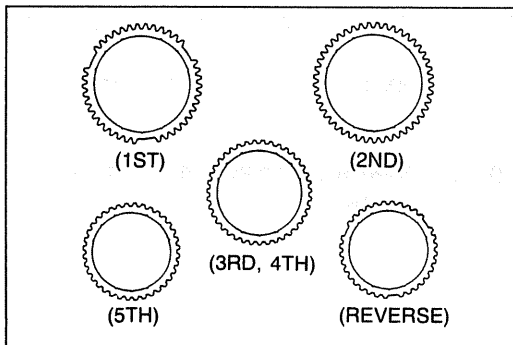

86U07A-076

Assembly note
Synchronizer key

Note

- There are two (2) types of synchronizer key.

Standard dimension:

mm (in)

	①	②
1st/2nd	22.0 (0.87)	14.2 (0.56)
3rd/4th, 5th/Rev.	17.0 (0.67)	12.2 (0.48)

Note

- The styles and sizes of synchronizer rings are different as shown in the illustration.

Synchronizer ring and clutch hub assembly

Note

- Align the synchronizer ring groove and clutch hub key when installing.

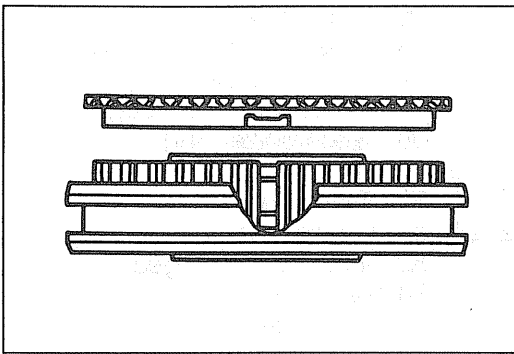

86U07A-159

Primary shaft gear

Synchronizer ring, 3rd gear and clutch hub assembly

1. Install the needle bearing and the primary 3rd gear.

Note

- Apply transaxle oil to the needle bearing.

2. Install the synchronizer ring and clutch hub assembly with the SST.

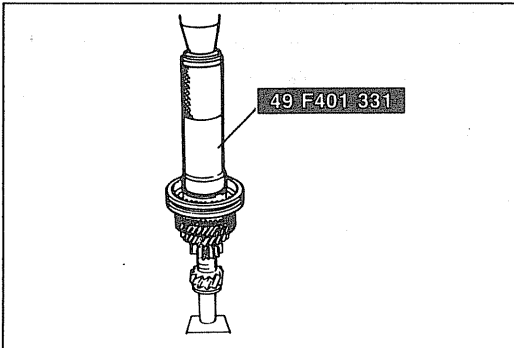

06U0J2-031

Synchronizer ring, 4th gear and bearing inner race

1. Install the synchronizer ring.
2. Install the ball and gear sleeve.
3. Install the needle bearing and the primary 4th gear.

Note

- Apply transaxle oil to the needle bearing.

4. Install the new bearing inner race with the SST.

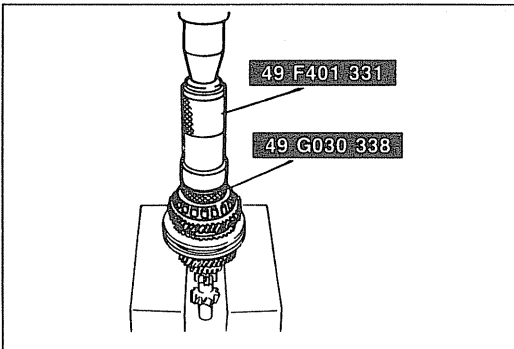

06U0J2-032

Bearing inner race

1. Install the new bearing inner race with the SST.

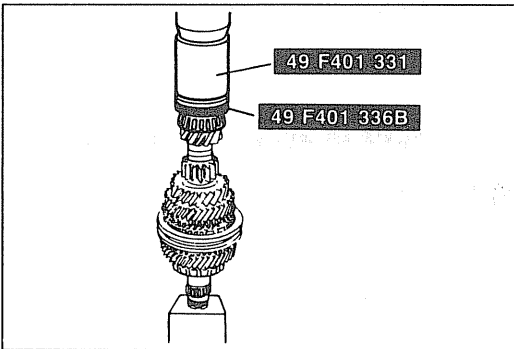

06U0J2-033

2. Measure the clearance between the primary 3rd gear and primary shaft gear.

If clearance is not within specification, replace any part which is worn or damaged.

Clearance: 0.150—0.262mm (0.0059—0.0103 in)

Maximum: 0.3mm (0.012 in)

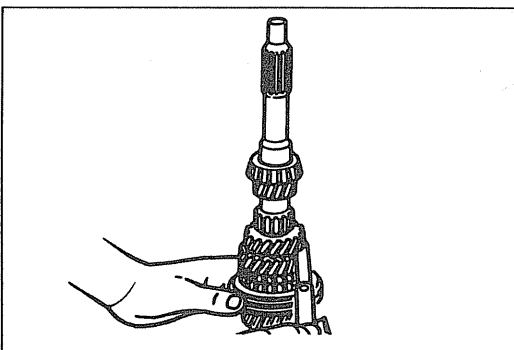

06U0J2-034

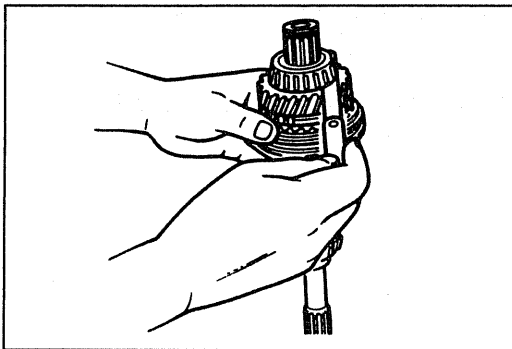

06U0J2-035

3. Measure the clearance between the primary 4th gear and bearing inner race. If clearance is not within specification replace any part which is worn or damaged.

Clearance: 0.150—0.262mm (0.0059—0.0103 in)
Maximum: 0.3mm (0.012 in)

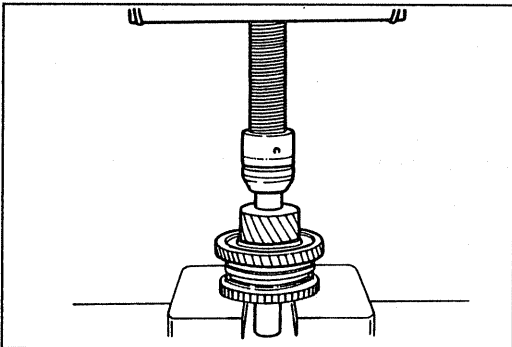

06U0J2-036

Secondary shaft gear

Secondary 1st gear, synchronizer ring and clutch hub assembly

1. Install the thrust washer.
2. Install the needle bearing and the secondary 1st gear.

Note

- Apply transaxle oil to the needle bearing.

3. Install the synchronizer ring (Refer to page J2-29.) and clutch hub assembly (reverse gear).

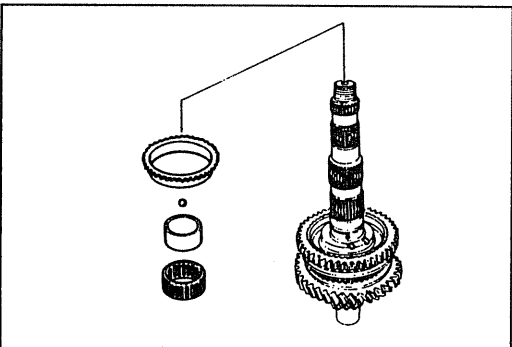

86U07A-166

4. Install the synchronizer ring.
5. Install the ball, gear sleeve and needle bearing.

Note

- Apply transaxle oil to the needle bearing.

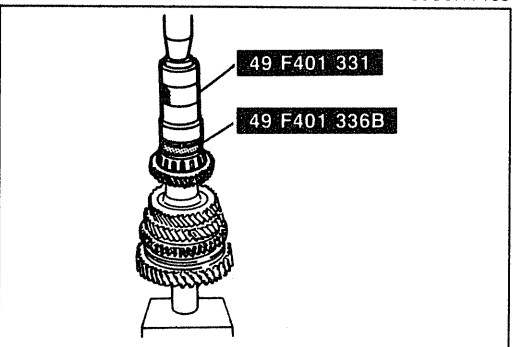

06U0J2-037

Secondary 3rd gear, 4th gear and bearing inner race

1. Install the secondary 3rd gear, spacer and the secondary 4th gear.
2. Install the bearing inner race with the SST.

Note

- Check that the spacer does not rotate.

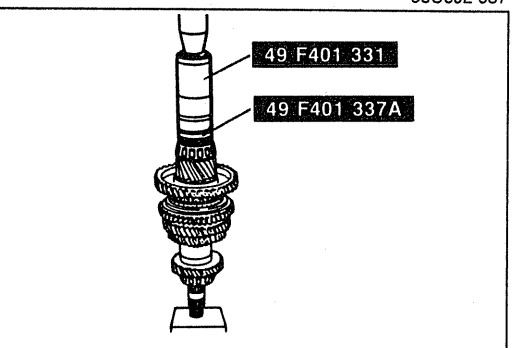

06U0J2-038

Bearing inner race

1. Install the new bearing inner race with the SST.

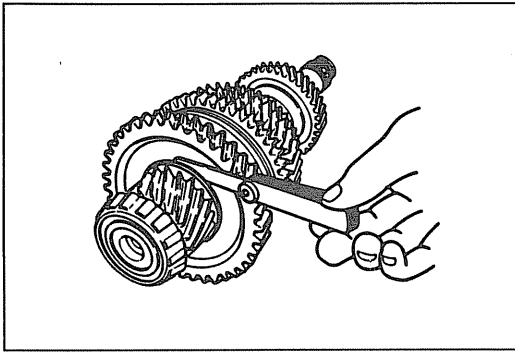

06U0J2-039

2. Measure the clearance between the secondary 1st gear and thrust washer.

Clearance: 0.130—0.354mm (0.0051—0.0139 in)
Maximum: 0.404mm (0.0159 in)

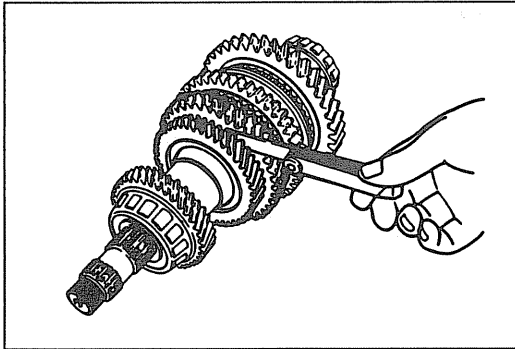

06U0J2-040

3. Measure the clearance between the secondary 2nd gear and secondary 3rd gear.
If clearance is not within specification, replace any part which is worn or damaged.

Clearance: 0.150—0.262mm (0.0059—0.0103 in)
Maximum: 0.3mm (0.012 in)

Step 3

1. Select the adjust shim(s), referring to **Bearing Preload Adjustment**.
2. Assemble in the order shown in the figure, referring to **Assembly Note**.

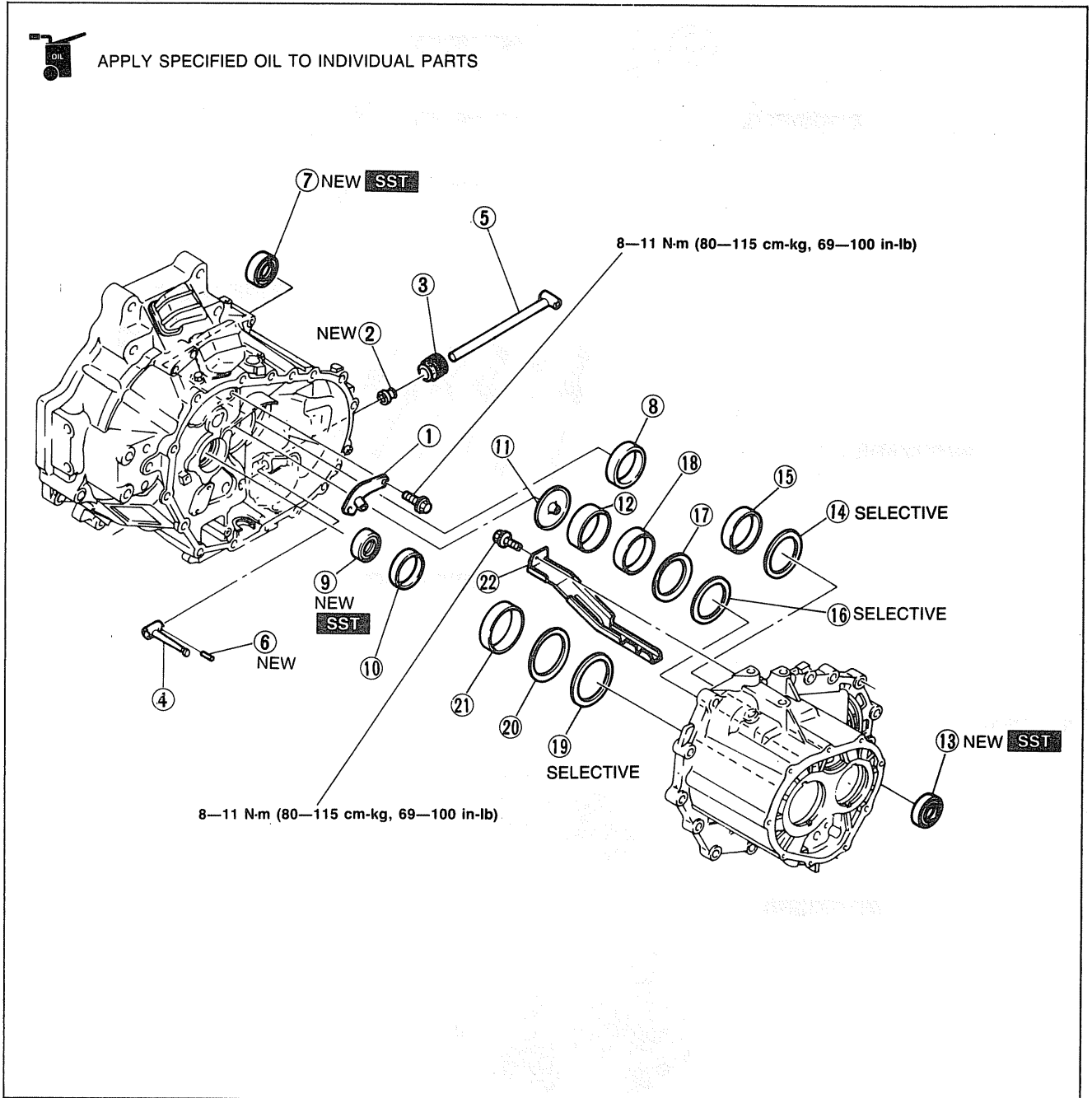

16U0J2-016

- | | | |
|------------------------------|------------------------------|------------------------------|
| 1. Baffle plate | 8. Bearing outer race | 16. Adjust shim |
| 2. Oil seal | Installation..... page J2-38 | 17. Diaphragm spring |
| 3. Boot | 9. Oil seal | 18. Bearing outer race |
| Installation..... page J2-37 | Installation..... page J2-38 | Installation..... page J2-37 |
| 4. Change arm | 10. Bearing outer race | 19. Adjust shim |
| Installation..... page J2-37 | 11. Funnel | 20. Diaphragm spring |
| 5. Change rod | 12. Bearing outer race | 21. Bearing outer race |
| Installation..... page J2-37 | 13. Oil seal | Installation..... page J2-37 |
| 6. Roll pin | Installation..... page J2-37 | 22. Oil passage |
| Installation..... page J2-38 | 14. Adjust shim | |
| 7. Oil seal | 15. Bearing outer race | |
| Installation..... page J2-38 | Installation..... page J2-38 | |

Bearing Preload Adjustment

When any of following parts are replaced, the bearing preload should be checked and adjusted.

SST

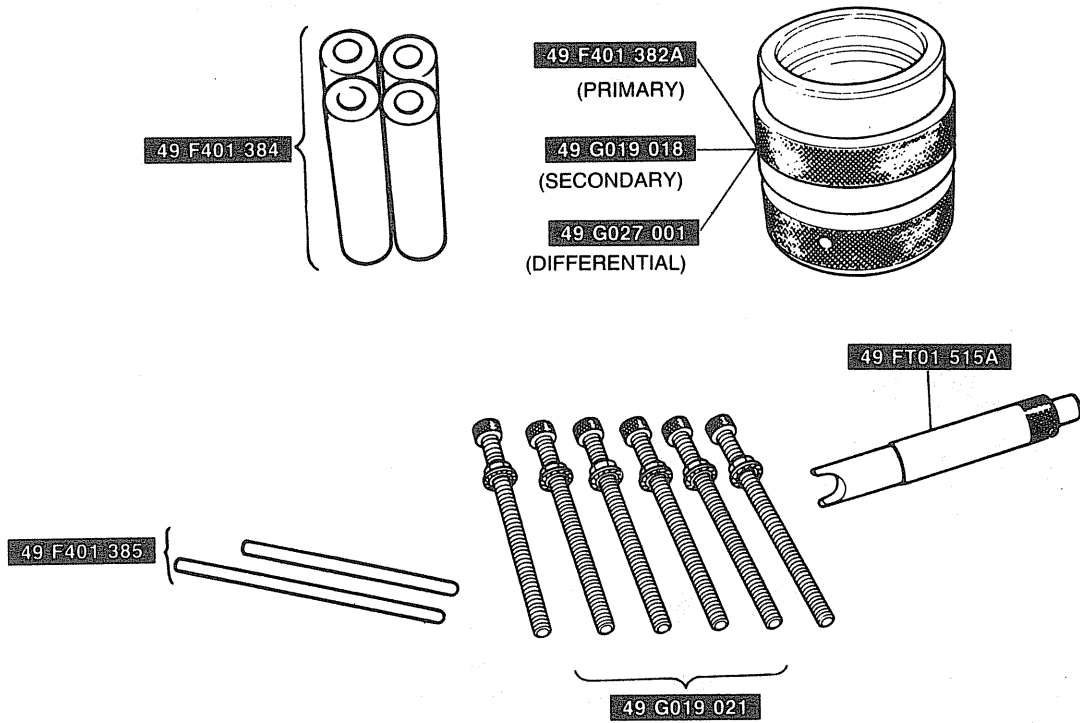

86U07A-178

SST USAGE

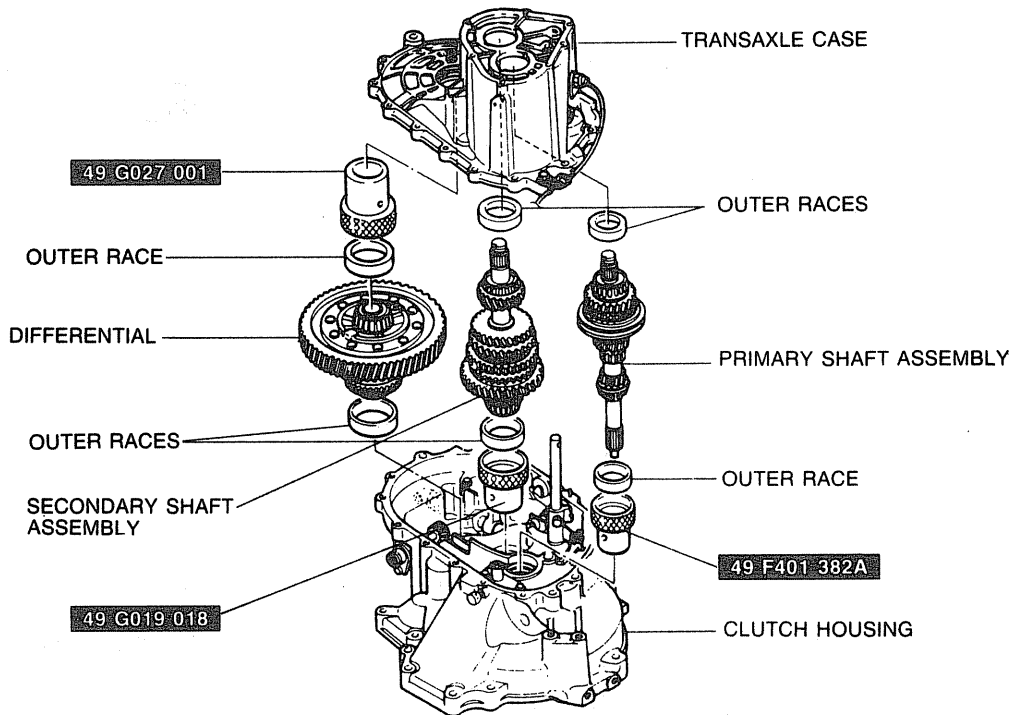

76G07A-639

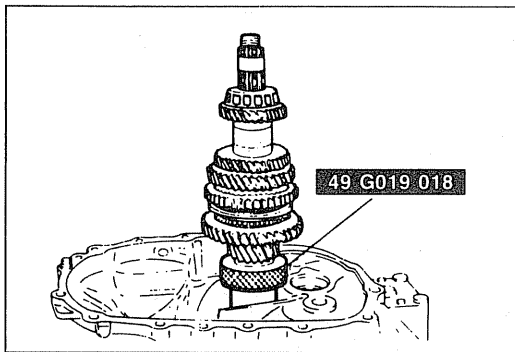

76G07A-640

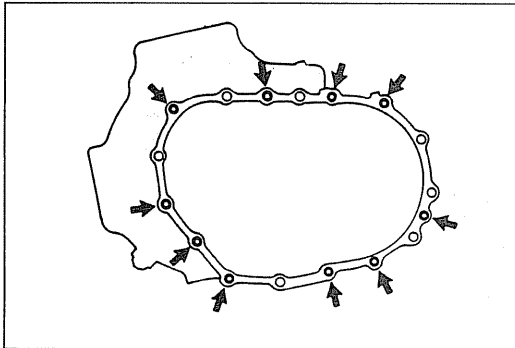

76G07A-641

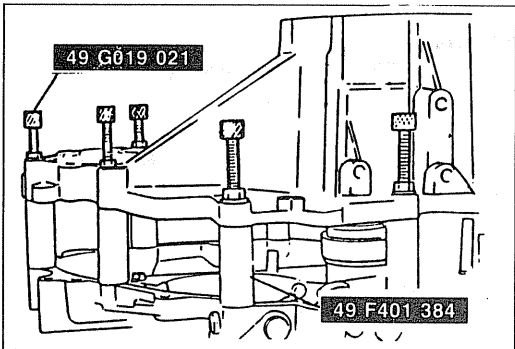

86U07A-181

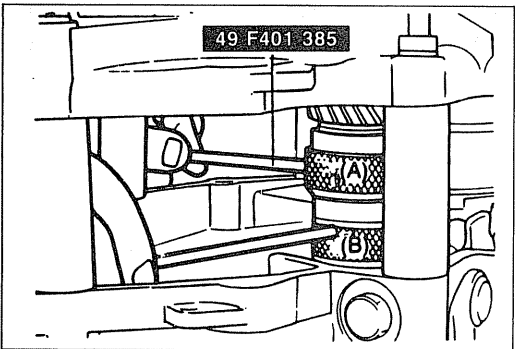

76G07A-642

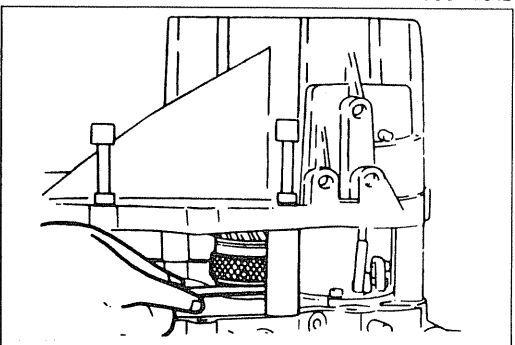

76G07A-643

1. Put the outer race into the **SST**.
2. Mount the secondary shaft gear assembly as shown.

Note

- The secondary shaft selector touches the differential gear, so the secondary shaft bearing preload adjustment should be done separately from for the primary shaft and differential assembly.

Note

- Install with the SST in the positions in the figure.

3. Install the transaxle case and set the **SST**.

Tightening torque:

37—52 N·m (3.8—5.3 m·kg, 27—38 ft·lb)

4. To seat the bearings, mount the **SST** on parts (A) and (B) of the selector, and then turn the selector so the gap is widened. Move the bar by hand until the selector can no longer be turned, and then turn it in the reverse direction until the gap is eliminated.
5. Manually expand the selector until the selector no longer turns.

Note

- Check that each shaft turns smoothly.

6. Use a thickness gauge to measure the gap of the selector.

Note

- Measure the gap around the entire circumference of the selector.

Thickness (Primary and Secondary)	
0.25mm (0.010 in)	0.55mm (0.022 in)
0.30mm (0.012 in)	0.60mm (0.024 in)
0.35mm (0.014 in)	0.65mm (0.026 in)
0.40mm (0.016 in)	0.70mm (0.028 in)
0.45mm (0.018 in)	0.75mm (0.030 in)
0.50mm (0.020 in)	0.80mm (0.031 in)

16U0J2-017

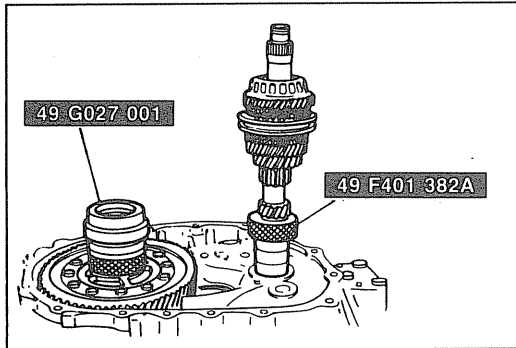

76G07A-645

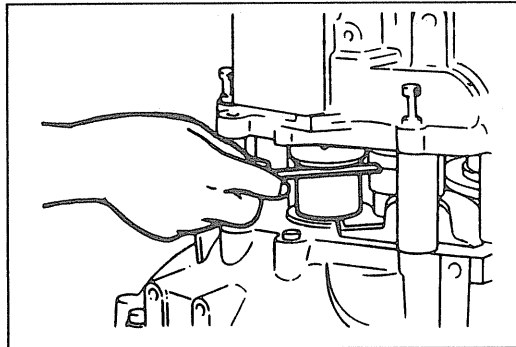

16U0J2-018

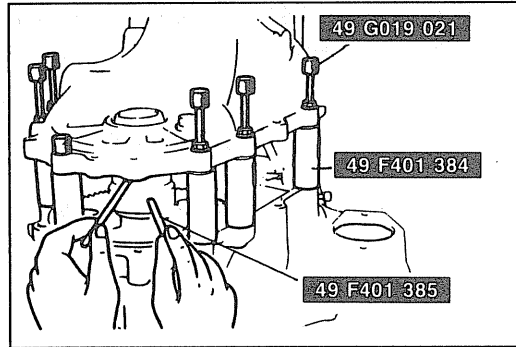

86U07A-189

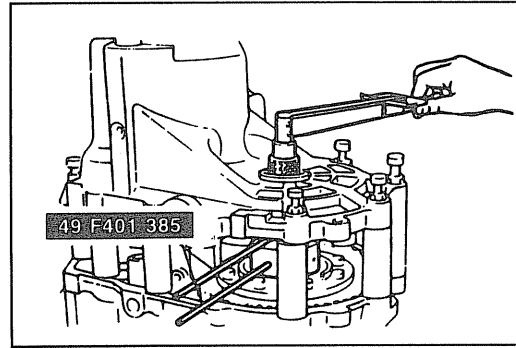

76G07A-619

7. Select the shim for the shaft gear by referring to the table and selecting the shim which is nearest (on the thick or thin side as shown) to the value obtained when subtracting the thickness of the diaphragm spring which goes between the shim and the race, from the measurement of the gap in the SST.

Secondary shaft

Example: 1.18mm (0.047 in)

$$1.18\text{mm (0.047 in)} - [\text{Diaphragm spring}] \\ 0.70\text{mm (0.028 in)} = 0.48\text{mm (0.019 in)}$$

So the nearest shim (on the thick side) to 0.48mm (0.019 in) is 0.50mm (0.020 in).

Note

- Use a maximum of two shims.

8. Remove the SST and the transaxle case.
9. Mount the differential assembly, the primary shaft gear assembly and the SST as shown in the figure.
10. Adjust the primary shaft preload in the same manner as that of the secondary shaft.

Primary shaft

Example: 1.18mm (0.047 in)

$$1.18\text{mm (0.047 in)} - [\text{Diaphragm spring}] \\ 0.70\text{mm (0.028 in)} = 0.48\text{mm (0.019 in)}$$

So the nearest shim (on the thin side) to 0.48mm (0.019 in) is 0.45mm (0.018 in).

Note

- Use a maximum of two shims.

11. Move the bars and expand the SST until it can no longer be turned, then turn it in the reverse direction until the gap is eliminated.

12. Set the SST.
13. Expand the selector with the bar until preload specification is obtained.

Preload: 0.5 N·m (5 cm·kg, 4.3 in·lb)

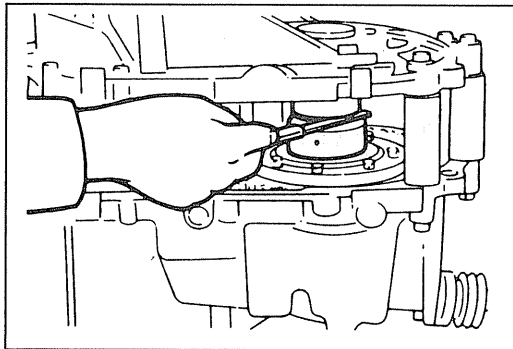

86U07A-191

Thickness (Differential)	
0.10mm (0.004 in)	0.65mm (0.026 in)
0.12mm (0.005 in)	0.70mm (0.028 in)
0.14mm (0.006 in)	0.75mm (0.030 in)
0.16mm (0.006 in)	0.80mm (0.031 in)
0.20mm (0.008 in)	0.85mm (0.033 in)
0.25mm (0.010 in)	0.90mm (0.035 in)
0.30mm (0.012 in)	0.95mm (0.037 in)
0.35mm (0.014 in)	1.00mm (0.039 in)
0.40mm (0.016 in)	1.05mm (0.041 in)
0.45mm (0.018 in)	1.10mm (0.043 in)
0.50mm (0.020 in)	1.15mm (0.045 in)
0.55mm (0.022 in)	1.20mm (0.047 in)
0.60mm (0.024 in)	

96U07A-037

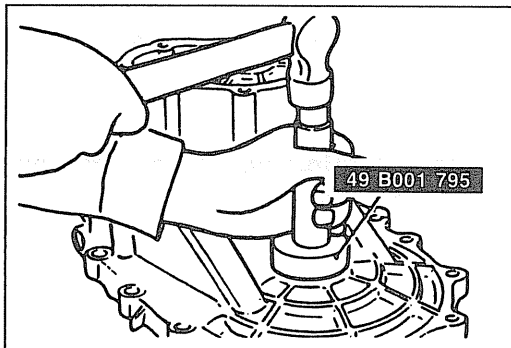

06U0J2-042

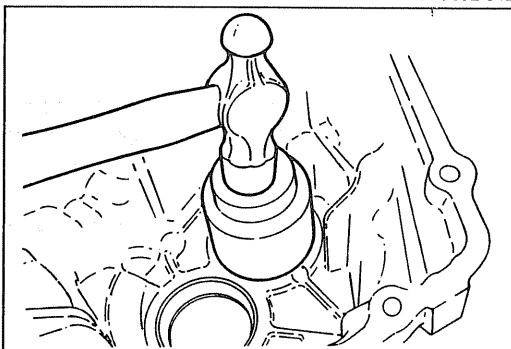

16U0J2-019

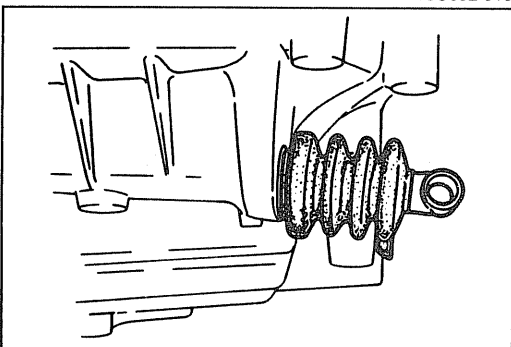

06U0J2-044

14. Use a thickness gauge to measure the gap in the selector for both gears.

Note

- Measure the gap around the entire circumference of the selector.

15. Add **0.15mm (0.0059 in)** to the measured clearance and select the combination of shims closest in value to that measurement.

See the table below for available shim sizes.

Example: 0.32mm (0.013 in)

$$0.32\text{mm (0.013 in)} + 0.15\text{mm (0.006 in)} = 0.47\text{mm (0.019 in)}$$

So the nearest shim (on the thick side) to 0.47mm (0.019 in) is 0.50mm (0.020 in).

Note

- Use a maximum of two shims.

Assembly note

Oil seal

Install the new oil seal with the SST.

Bearing outer races

Tap the primary and secondary shaft bearing outer races in until they are fully seated with a suitable pipe.

Note

- Install the primary and secondary shaft bearing outer race and diaphragm springs and adjust shims after adjusting the bearing preload.

Change arm, boot and change rod

Install the change arm, boot and change rod.

Note

- Install the boot with the air bleed downward as shown in the figure.

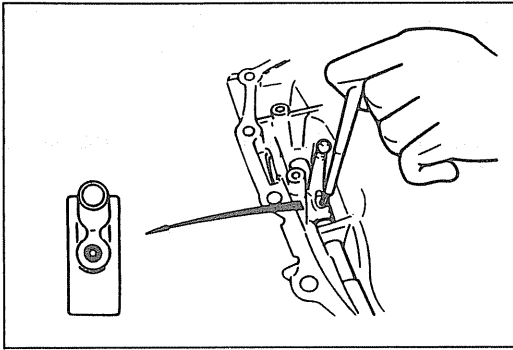

06U0J2-045

Roll pin

Install the new roll pin as shown in the figure.

Note

- Roll pin length is 28mm (1.10 in).

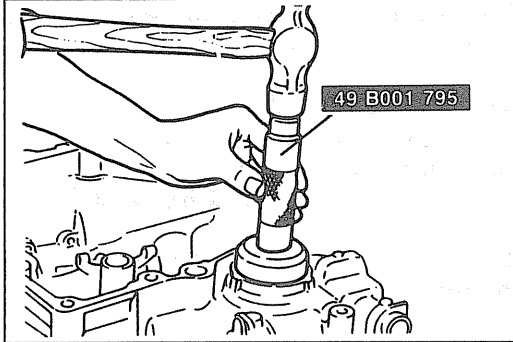

06U0J2-046

Oil seals

1. Tap the new oil seal (differential) with the **SST**.
2. Tap the new oil seal (primary shaft) with a suitable pipe.

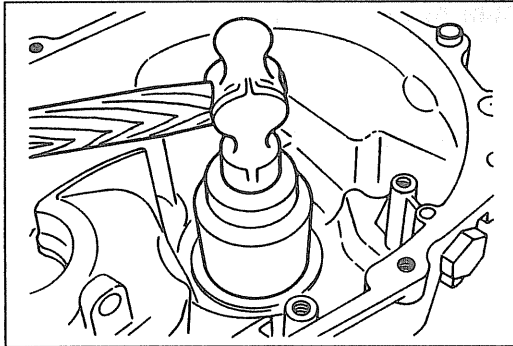

16U0J2-020

Bearing outer race

Tap the differential bearing outer race in until it is fully seated with a suitable pipe.

Note

- Install the differential bearing outer races, after adjusting the bearing preload.

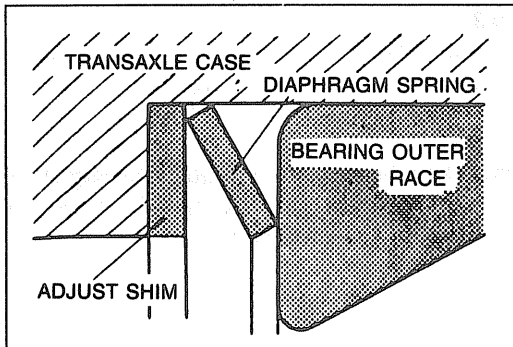

86U07A-193

Rechecking of bearing preload

1. Remove the **SST** and transaxle.
2. Remove the bearing outer races from the transaxle case.
3. Install the primary and secondary adjust shims, diaphragm springs and bearing outer races to the case as shown in the figure.
4. Install the differential adjust shim(s) and bearing outer race to the case.
5. Install the primary and secondary bearing outer races to the clutch housing.
6. Install the primary shaft gear assembly and the differential assembly.
7. Install the transaxle case and tighten the specified torque.

Tightening torque:

37—52 N·m (3.8—5.3 m·kg, 27—38 ft·lb)

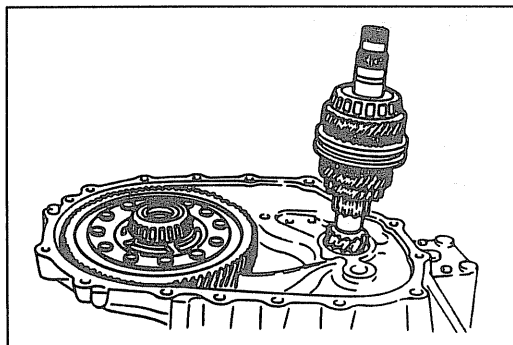

76G07A-647

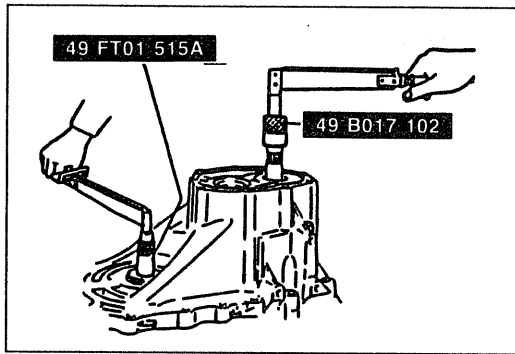

96U07A-038

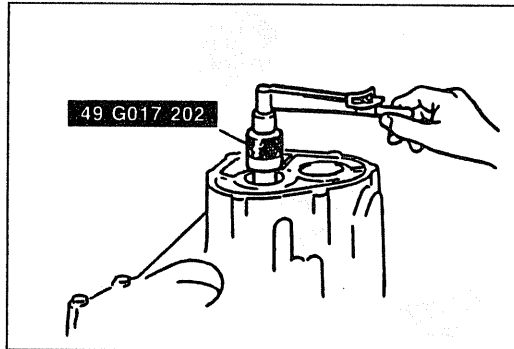

96U07A-039

8. Connect the **SST**.
9. Check that the preload is within the specified range.

Primary shaft:

0.1—0.25 N·m (1.0—2.5 cm·kg, 0.87—2.17 in·lb)

Differential:

1.4—2.0 N·m (14—20 cm·kg, 12.2—17.4 in·lb)

10. Check secondary shaft preload in the same manner as that of the primary shaft.

Secondary shaft:

0.2—0.4 N·m (2.0—4.0 cm·kg, 1.74—3.47 in·lb)

Step 4

1. Assemble in the order shown in the figure, referring to **Assembly Note**.

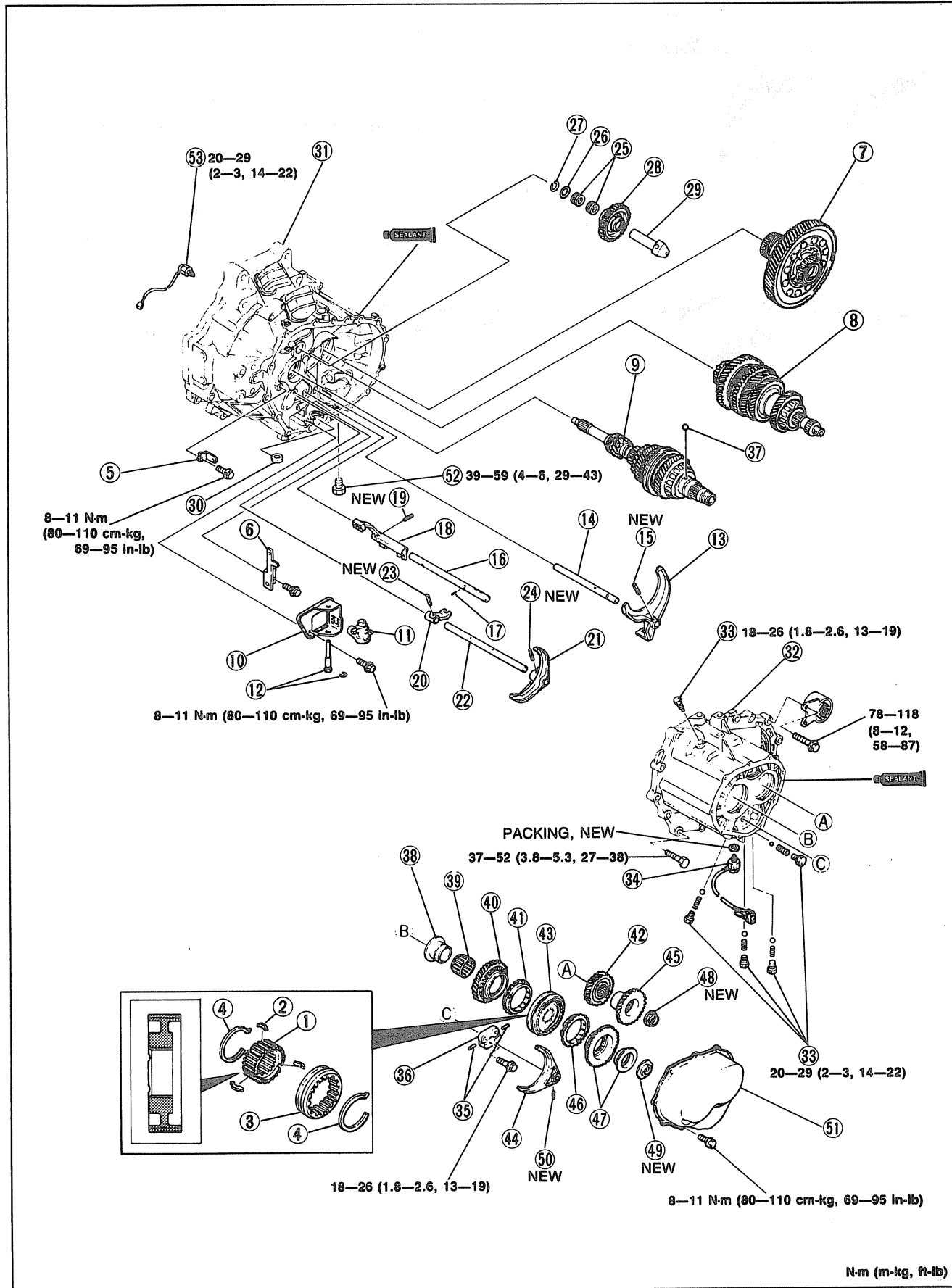

- | | | |
|---|---|--|
| 1. Clutch hub | 21. Shift fork (3rd/4th) | 38. Gear sleeve |
| 2. Synchronizer key | 22. Shift rod (3rd/4th) | 39. Needle bearing |
| 3. Clutch hub sleeve | 23. Roll pin | 40. Primary 5th gear |
| 4. Synchronizer key spring | 24. Roll pin | 41. Synchronizer ring |
| 5. Lever set spring | 25. Needle bearings | 42. Secondary 5th gear |
| 6. Reverse shift lever | 26. Washer | 43. Clutch hub assembly (5th/Rev.)
Installation..... page J2-42 |
| 7. Differential assembly | 27. Snap ring | 44. Shift fork (5th/Rev.)
Installation..... page J2-42 |
| 8. Secondary shaft gear assembly | 28. Reverse idler gear
Installation..... page J2-41 | 45. Secondary reverse synchronizer gear |
| 9. Primary shaft gear assembly | 29. Reverse idler shaft
Installation..... page J2-41 | 46. Synchronizer ring |
| 10. Base plate unit
Installation..... page J2-41 | 30. Magnet | 47. Primary reverse synchronizer gear and gear sleeve |
| 11. Crank lever assembly
Installation..... page J2-41 | 31. Clutch housing
Installation..... page J2-42 | 48. Locknut
Installation..... page J2-42 |
| 12. Crank lever shaft and snap ring
Installation..... page J2-41 | 32. Transaxle case | 49. Locknut
Installation..... page J2-42 |
| 13. Shift fork (1st/2nd) | 33. Bolt(s), spring(s) and ball(s) | 50. Roll pin |
| 14. Shift rod (1st/2nd) | 34. Reverse switch | 51. Rear cover |
| 15. Roll pin | 35. Interlock pins
Installation..... page J2-42 | 52. Drain plug |
| 16. Shift rod (5th/Rev.) | 36. Interlock plate
Installation..... page J2-42 | 53. Neutral switch |
| 17. Interlock pin | 37. Ball | |
| 18. Shift rod end (5th/Rev.) | | |
| 19. Roll pin | | |
| 20. Shift rod end (3rd/4th) | | |

06U0J2-048

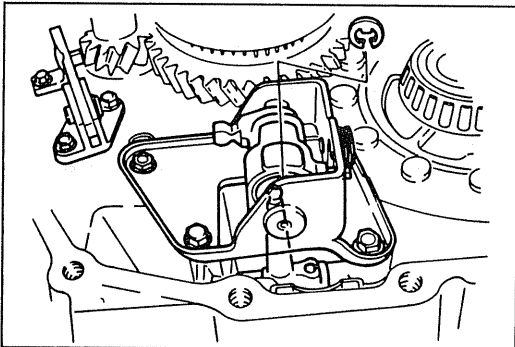

06U0J2-049

Assembly note

Base plate unit, crank lever assembly and crank lever shaft

Install the base plate unit, the crank lever assembly and the crank lever shaft.

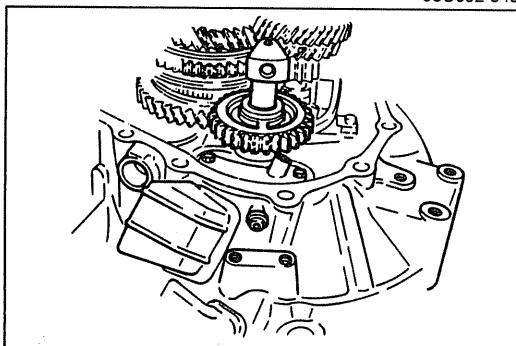

06U0J2-050

Reverse idler gear and reverse idler shaft

Set the reverse idler gear and the reverse idler shaft in the direction shown.

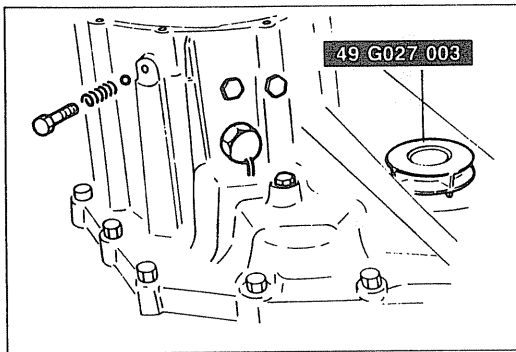

06U0J2-051

Clutch housing

Install the **SST** to driveshaft coupling hole.

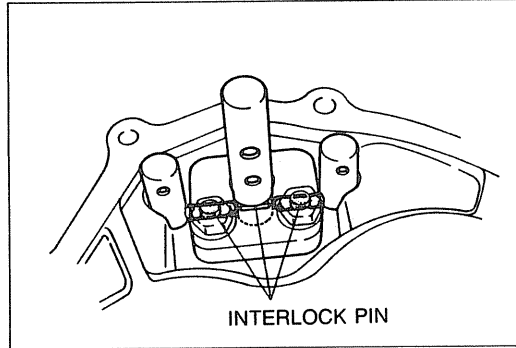

INTERLOCK PIN

06U0J2-052

Interlock pins and Interlock plate

1. Install the interlock pins.
2. Install the interlock plate.

Tightening torque:

18—26 N·m (1.8—2.6 m·kg, 13—19 ft·lb)

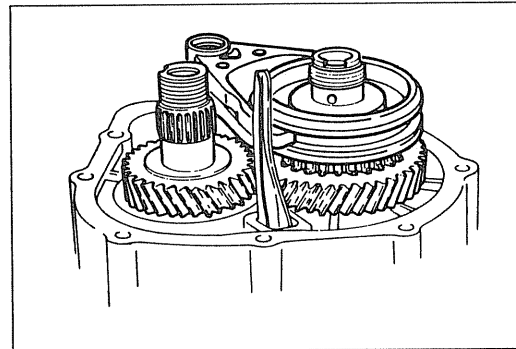

06U0J2-053

Clutch hub assembly and shift fork

Install the clutch hub assembly and the shift fork together.

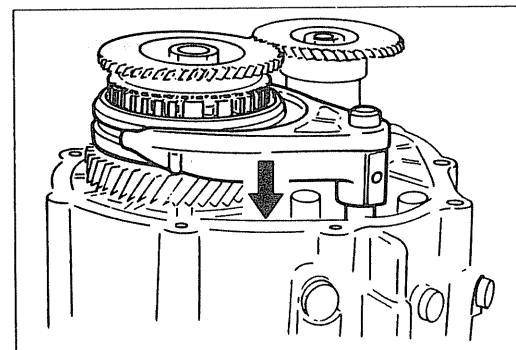

06U0J2-054

Locknuts

1. Shift to the 5th gear and the 1st gear.
2. Tighten the new locknuts and stake them.

Tightening torque:

128—196 N·m (13.0—20.0 m·kg, 94—145 ft·lb)

INSTALLATION

1. Install in the reverse order of removal, referring to **Installation Note**.
2. After installation, fill the transaxle with the specified oil.

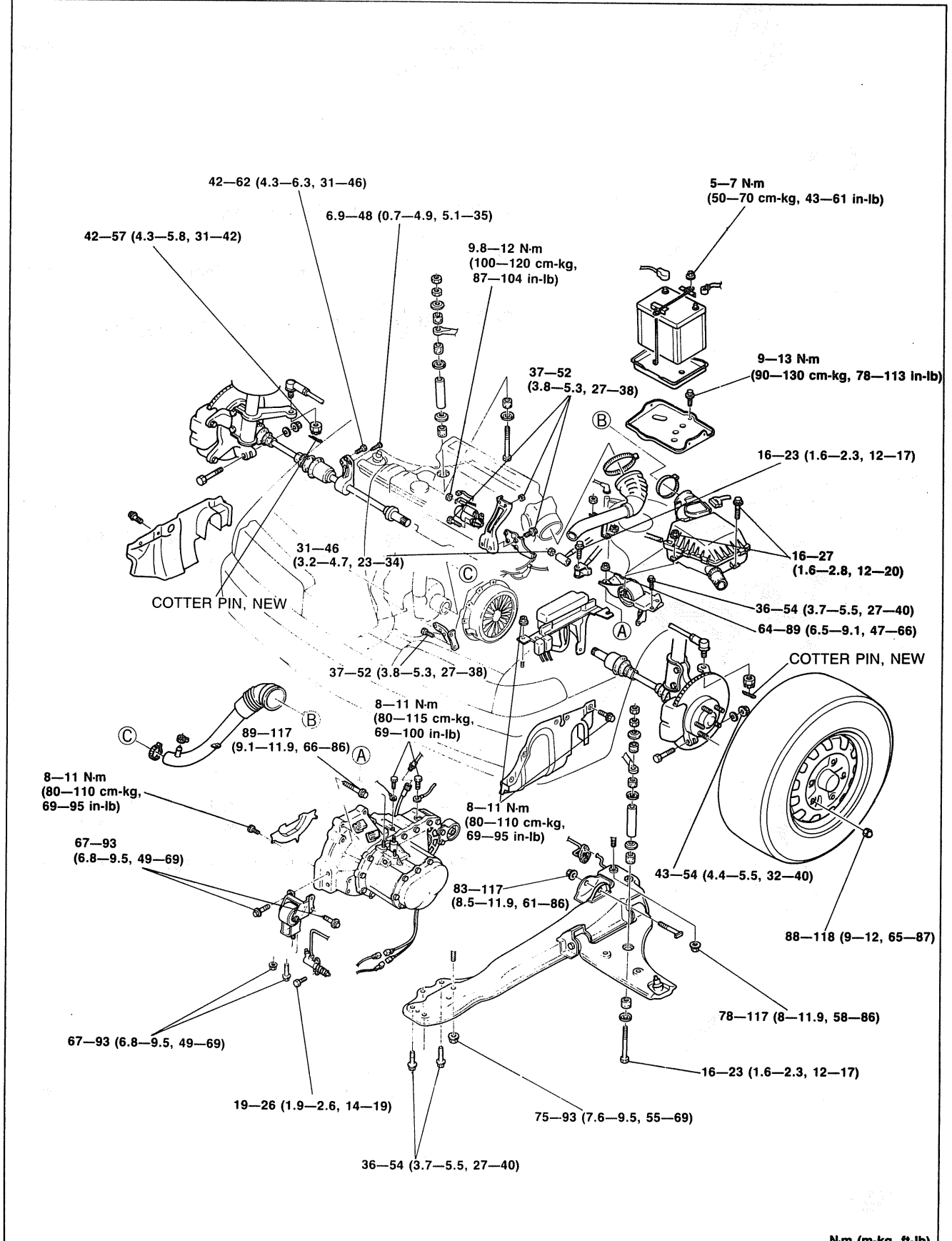

N-m (m-kg, ft-lb)

06U0J1-077

J2-43

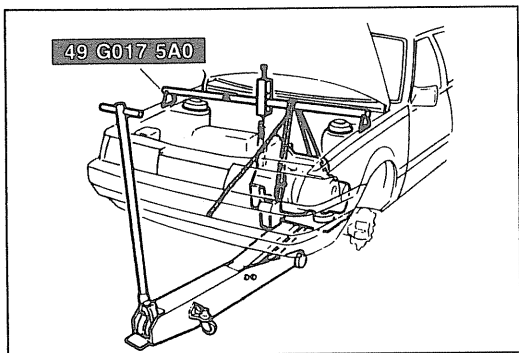

06U0J1-078

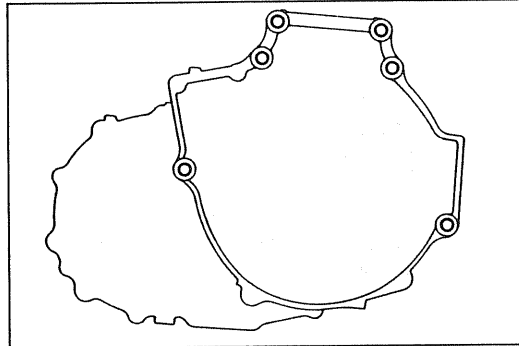

96U07A-040

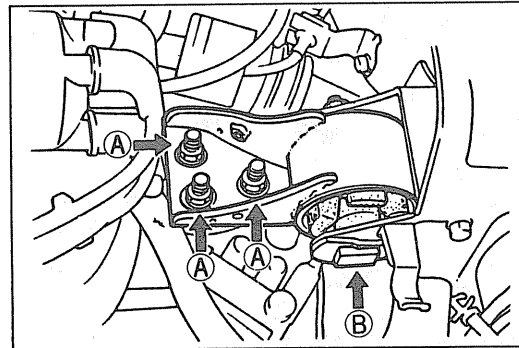

76F07A-062

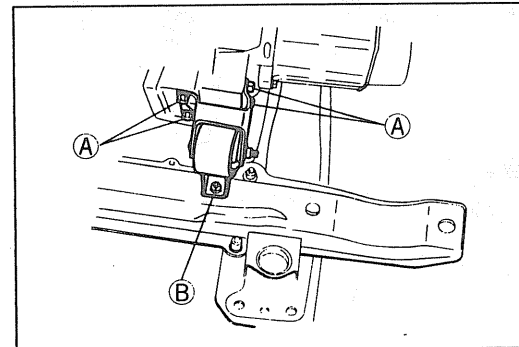

06U0J2-055

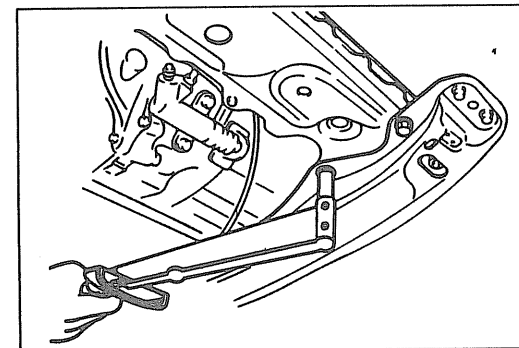

86U07A-214

Installation note

1. Attach rope at 2 places on the transaxle and place a board on the jack and position the transaxle on it.

Caution

- The transaxle is not well balanced; be careful when positioning on the jack.

2. Move the transaxle into the place and attach the rope (attached to the transaxle in step 1) to the **SST**.

3. Install the transaxle onto the engine.

Note

- Lift the transaxle using the jack to pull the rope.

Tightening torque:

89—117 N·m (9.1—11.9 m·kg, 66—86 ft·lb)

4. Install the engine mount No.4.

Tightening torque

(A) : 64—89 N·m (6.5—9.1 m·kg, 47—66 ft·lb)

(B) : 67—93 N·m (6.8—9.5 m·kg, 49—69 ft·lb)

5. Install the engine mount No.2.

Tightening torque

(A) : 67—93 N·m (6.8—9.5 m·kg, 49—69 ft·lb)

(B) : 67—93 N·m (6.8—9.5 m·kg, 49—69 ft·lb)

6. Install the crossmember and the left side lower arm as an assembly.

Tightening torque:

Bolts, 36—54 N·m (3.7—5.5 m·kg, 27—40 ft·lb)

Nut, 75—93 N·m (7.6—9.5 kg, 55—69 ft·lb)

7. Remove the jack and take off the rope.
8. Remove the **SST**.

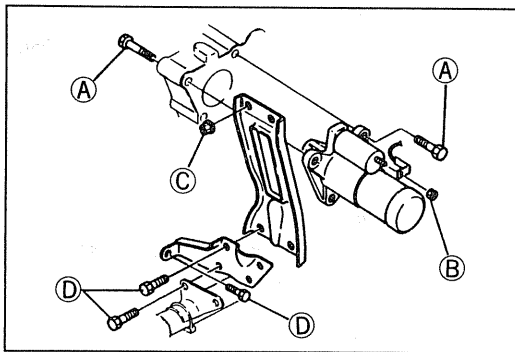

16U0J2-021

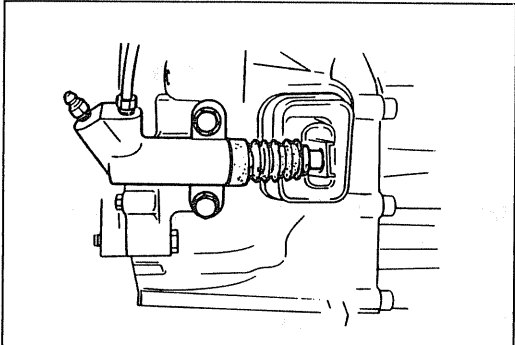

86U07A-216

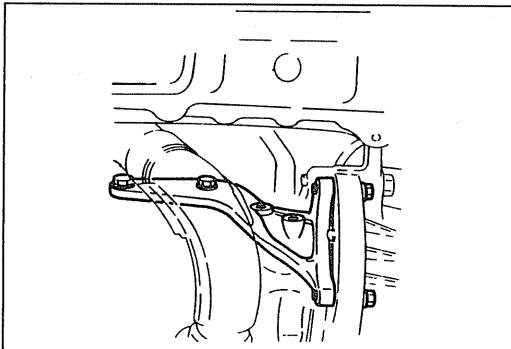

86U07A-217

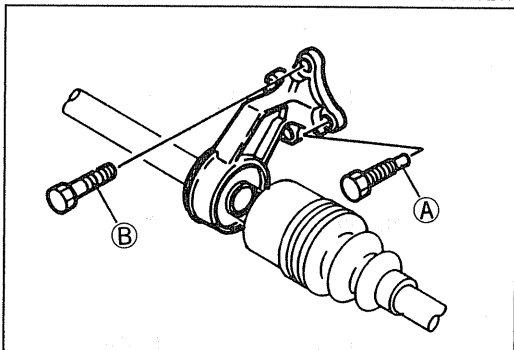

16U0J2-022

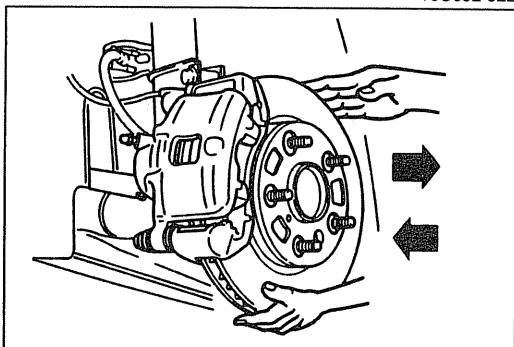

96U07A-048

9. Install the starter and harnesses.

Tightening torque

Ⓐ : 37—52 N·m (3.8—5.3 m·kg, 27—38 ft·lb)

Ⓑ : 9.8—12 N·m (100—120 cm·kg, 87—104 in·lb)

10. Install the surge tank bracket and the gusset plate.

Tightening torque

Ⓒ : 37—52 N·m (3.8—5.3 m·kg, 27—38 ft·lb)

Ⓓ : 37—52 N·m (3.8—5.3 m·kg, 27—38 ft·lb)

11. Install the end plate.

Tightening torque:

8—11 N·m (80—110 cm·kg, 69—95 in·lb)

12. Install the clutch release cylinder.

Tightening torque:

19—26 N·m (1.9—2.6 m·kg, 14—19 ft·lb)

13. Install the gusset plates.

Tightening torque:

37—52 N·m (3.8—5.3 m·kg, 27—38 ft·lb)

14. Replace the clips at the end of the driveshafts and joint shaft with new ones.

15. Install the joint shaft and right driveshaft as follows:

- (1) Install and tighten the reamer bolts Ⓐ; then install and tighten the standard bolts Ⓑ.

Tightening torque

Ⓐ : 6.9—48 N·m (0.7—4.9 m·kg, 5.1—35 ft·lb)

Ⓑ : 42—62 N·m (4.3—6.3 m·kg, 31—46 ft·lb)

(2) Remove the **SST** (holder) and insert the shaft into the transaxle.

(3) Pull the front hub outward and connect the driveshaft to the joint shaft.

(4) Push the joint at the differential side to securely connect the driveshaft to the joint shaft.

Note

- After installation, pull the front hub outward to confirm that the driveshaft doesn't come out.
- Do not damage the oil seal.

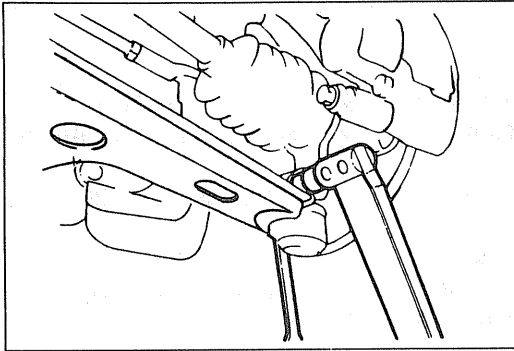

86U07A-220

16. Install the left driveshaft as follows:
- (1) Pull the front hub outward and insert the driveshaft into the transaxle.
 - (2) Push the joint at the differential side to connect the driveshaft to the differential side gear.

Note

- Do not damage the oil seal.
- After installation, pull the front hub outward to confirm that the driveshaft doesn't come out.

17. Install the lower arm ball joints to the knuckles and tighten the bolts and nuts.

Tightening torque:

36—54 N·m (3.7—5.5 m·kg, 27—40 ft·lb)

18. Install the under cover.

Note

- Before installation, fill the notches with silicon as shown in the figure.

Tightening torque:

8—11 N·m (80—110 cm·kg, 69—95 in·lb)

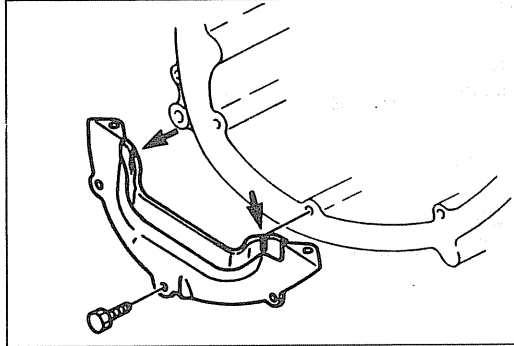

06U0J2-062

19. Install the stabilizer bar control links as follows.

- (1) Install the stabilizer bar control link.
- (2) Adjust protrusion to **20.1 ± 2mm (0.79 ± 0.08 in)**.
- (3) Tighten bolt to specified torque.

Tightening torque:

16—23 N·m (1.6—2.3 m·kg, 12—17 ft·lb)

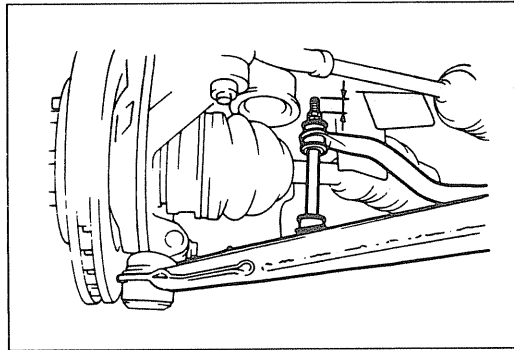

06U0J2-063

20. Install the tie-rod ends and new cotter pin.

Tightening torque:

42—57 N·m (4.3—5.8 m·kg, 31—42 ft·lb)

21. Install the splash shields.

Tightening torque:

8—11 N·m (80—110 cm·kg, 69—95 in·lb)

22. Install the front wheels.

Tightening torque:

88—118 N·m (9.0—12.0 m·kg, 65—87 ft·lb)

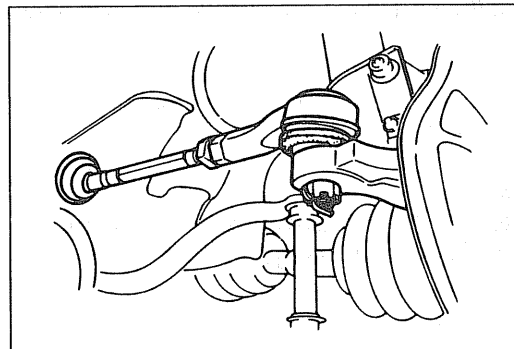

06U0J2-064

23. Install the grounds to the transaxle case.

Tightening torque:

8—11 N·m (80—115 cm·kg, 69—100 in·lb)

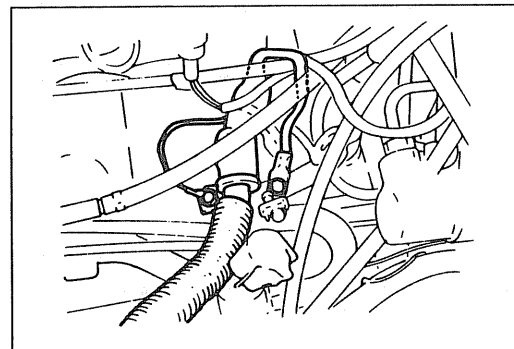

76G07A-652

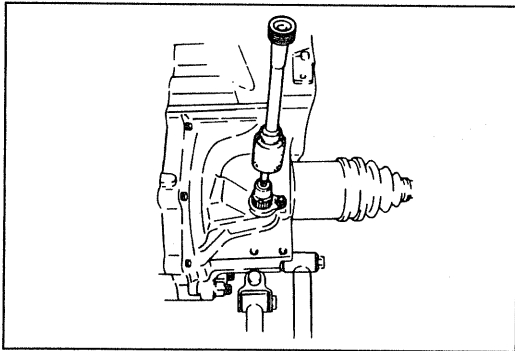

86U07A-225

24. Connect the speedometer cable.

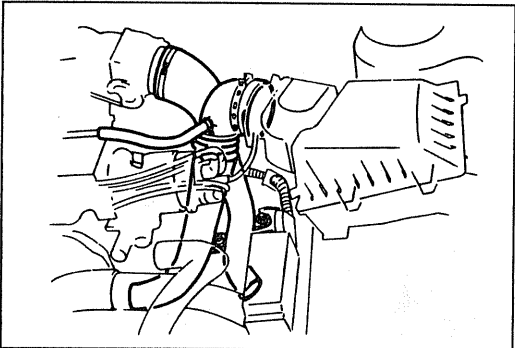

86U07A-226

25. Install the intercooler hoses as follows.
 (1) Air cleaner to turbocharger.
 (2) Inter cooler to throttle body.

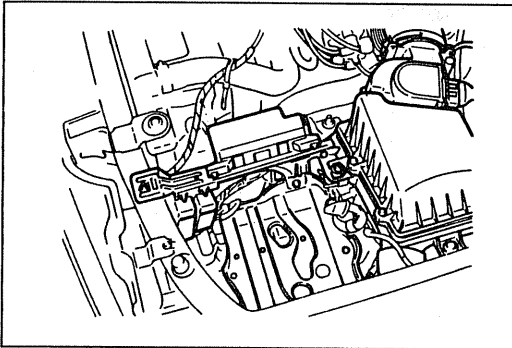

86U07A-227

26. Install the air cleaner assembly and connect the air flow meter connector.

Tightening torque:

8—11 N·m (80—110 cm·kg, 69—95 in·lb)

27. Connect the distributor lead.
 28. Connect the main fuse block.

Tightening torque:

8—11 N·m (80—110 cm·kg, 69—95 in·lb)

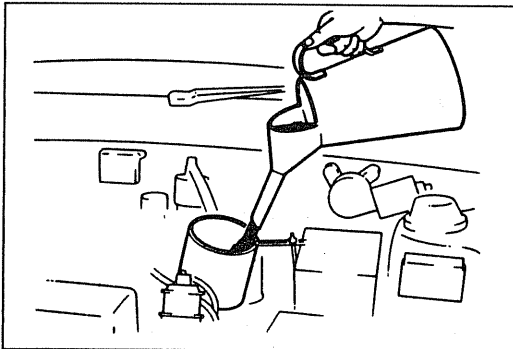

16U0J2-023

29. Install the battery carrier and battery.
 30. Add the correct quantity of the specified transaxle oil.

Specified oil

Type

All-season

SAE 75W-90

ATF: DEXRON-II

Above -18°C (0°F):

API: GL-4 or GL-5

SAE 80W-90 or SAE 90

Capacity: 3.65 liters (3.9 US qt, 3.2 Imp qt)

SHIFT MECHANISM

REMOVAL / INSTALLATION

1. Jack up the vehicle and support it with safety stands.
2. Remove in the order shown in the figure, referring to **Removal Note**.
3. Install in the reverse order of removal, referring to **Installation Note**.

06U0J1-081

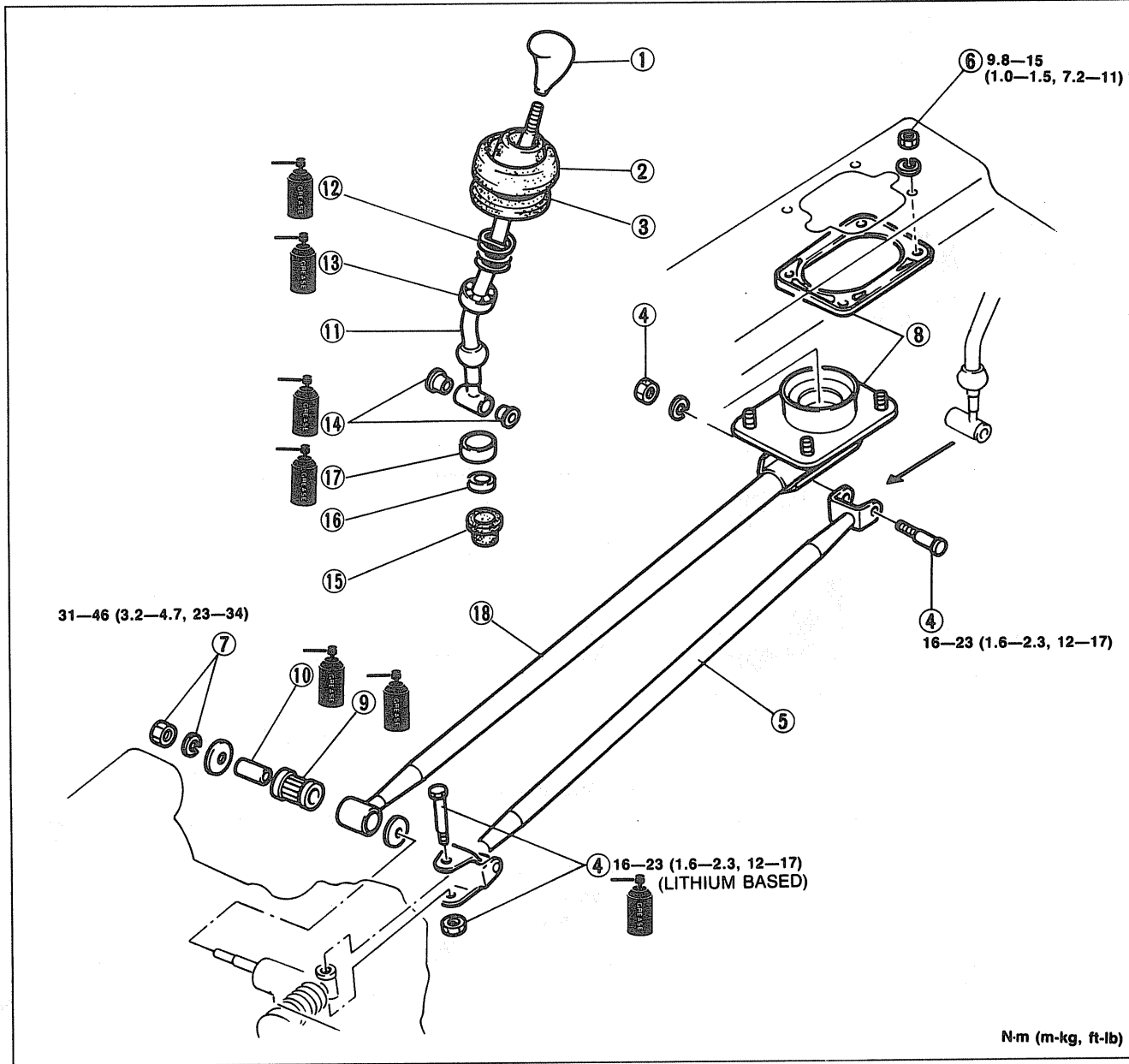

N·m (m·kg, ft·lb)

06U0J2-057

- | | | |
|------------------------------|--|------------------------------|
| 1. Change lever knob | 8. Extension bar bracket assembly and gasket | 14. Bushings |
| 2. Assist boot | Installation..... page J2-50 | 15. Boot |
| 3. Mounting rubber boot | | Installation..... page J2-49 |
| 4. Bolts and nuts | 9. Bushing | 16. Holder |
| 5. Change control rod | 10. Pipe | Installation..... page J2-49 |
| Installation..... page J2-50 | 11. Change lever | 17. Ball seat (lower) |
| 6. Bracket installation nuts | 12. Spring | Installation..... page J2-49 |
| Installation..... page J2-49 | Removal page J2-49 | 18. Extension bar |
| 7. Nut and washer | Installation..... page J2-50 | Installation..... page J2-49 |
| | 13. Ball seat (upper) | |
| | Installation..... page J2-49 | |

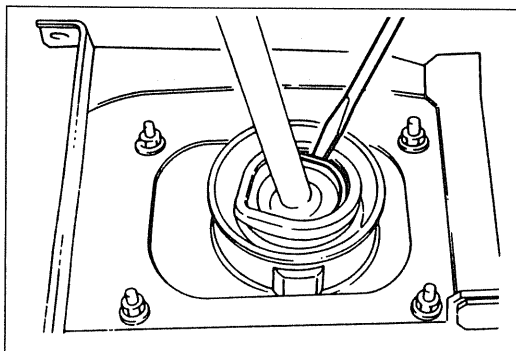

06U0J1-082

Removal note

Spring

Remove the spring by prying on the hooked part of the spring with a screwdriver.

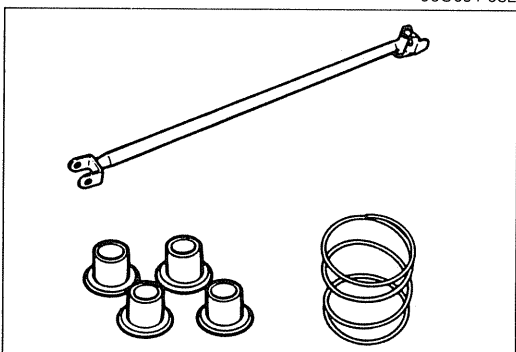

61G07X-192

INSPECTION

Check the following, and replace if necessary:

1. Bent control rod.
2. Wear, damage, or malfunction of any joint.
3. Damaged gear shift lever ball.
4. Weak spring.
5. Wear or damage of bushing.

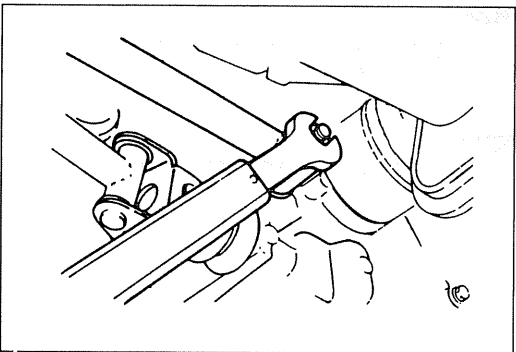

06U0J1-083

Installation note

Extension Bar

First, install the extension bar to the floor, and then install it onto the transaxle.

Tightening torque:

31—46 N·m (3.2—4.7 m·kg, 23—34 ft·lb)

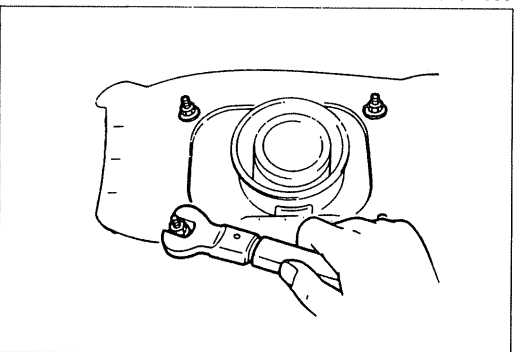

06U0J2-059

Bracket Installation

Tighten the bracket installation nuts to the specified torque.

Tightening torque:

9.8—15 N·m (1.0—1.5 m·kg, 7.2—11 ft·lb)

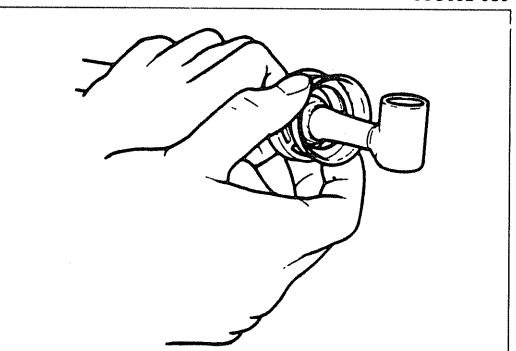

61G07X-193

Gear Shift Lever Ball

Apply grease to the ball seat surface, and install the upper and lower ball seat, holder, and boot.

Note

- Apply grease to all joints.

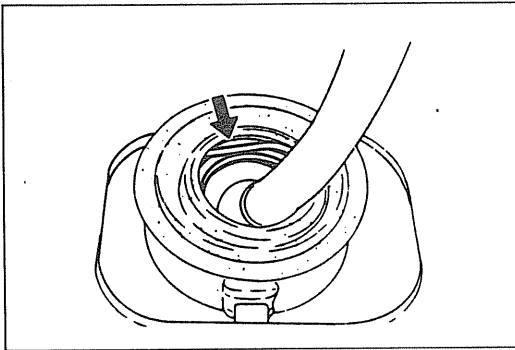

63U07A-156

Spring

Make sure that the hooked part of the spring is properly seated in the bracket groove, as shown in the figure.

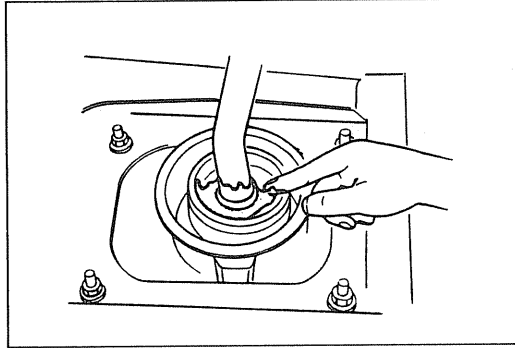

63U07A-157

Bracket Cavity

Put grease in the bracket cavity.

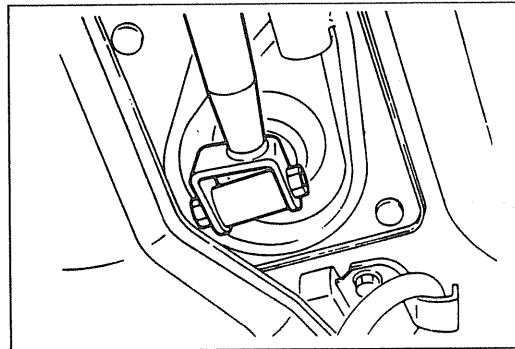

96U07X-044

Change Control Rod

Install the change control rod so that its relationship with the shift lever is as shown in the figure.

Tightening torque:

16—23 N·m (1.6—2.3 m·kg, 12—17 ft·lb)